

SIMPLE SURVEYING TECHNIQUES FOR  
SMALL EXPEDITIONS

*By*  
KEITH MILLER



## CONTENTS

<b>Preface</b>	<b>page</b>	<b>iii</b>
<b>Introduction</b>		<b>1</b>
<b>The three phases of an expedition</b>		<b>1</b>
<b>Survey instruments</b>		<b>6</b>
<b>The surveyor's record book</b>		<b>18</b>
<b>Field techniques</b>		<b>21</b>
<b>Computations</b>		<b>40</b>
<b>Special hints</b>		<b>46</b>
<b>Conclusion</b>		<b>50</b>
<b>Acknowledgements</b>		<b>50</b>
<b>References</b>		<b>50</b>
<b>Further reading</b>		<b>50</b>
<b>Appendix</b>		<b>52</b>



PLATE I



*Recommended posture for viewing through a telescope*



PLATE II

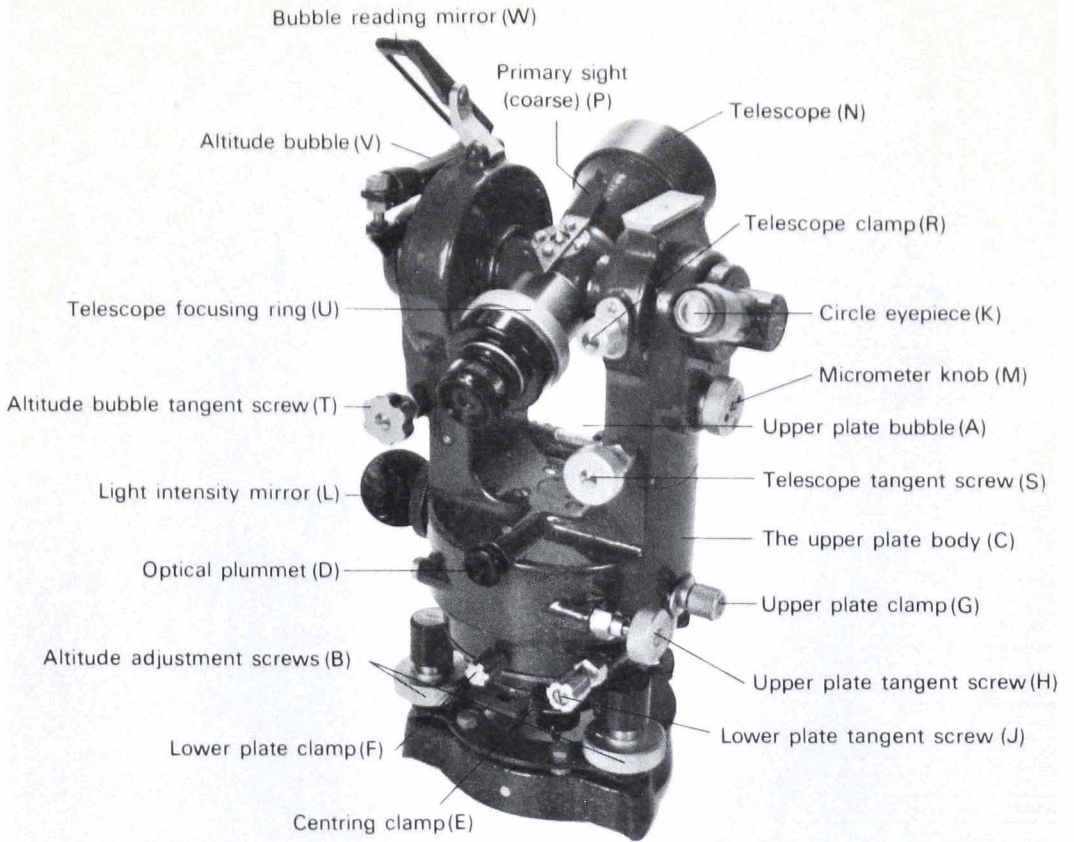

*Important features of the microptic theodolite*

## PREFACE

D. N. HALL

Chairman, RGS Survey and Instruments Committee

The Royal Geographical Society helps many expeditions to prepare for work in the field, and the purpose of this paper is to assist the surveyor, especially one with little experience.

To achieve the best possible results, it is essential for expeditions to have surveyors who are trained to a high level of ability. However, some expeditions have to do the best they can with members who have done little more than elementary map reading. It was felt that a paper in the current series of expedition pamphlets could usefully point out the need for careful planning and suggest further reading. Using the equipment and simple techniques outlined in the paper, the surveyor should be able to produce a map plus full and accurate records, which should also give valuable support to the other scientific disciplines of the expedition.





# SIMPLE SURVEYING TECHNIQUES FOR SMALL EXPEDITIONS

KEITH MILLER  
Trinity College, Cambridge

## INTRODUCTION

The most widely useful piece of information that can be derived from an expedition is a map of the area visited. Such a map will be of immense value for collating information for publication in an expedition report, journal or book, not to mention the pleasure the map will give a reader, who thereby gains a pictorial appreciation of the terrain visited. Furthermore, a map, if drawn during the course of the expedition, can be of immediate use to other members of the expedition whilst working on their individual projects. Finally, the map will be of immense value to future explorers of the area since it will assist them to extend the boundaries of knowledge previously set by your expedition. It follows, therefore, that one of the major responsibilities of any expedition is to record, as efficiently and accurately as possible, data that will bring sense and order to an area where, previously, neither appeared to exist. This article is written with the intention of assisting you to achieve that objective and provide guide-lines and hints to help with the production of a map. It is assumed that no member of your expedition has trained as a surveyor and that the one or two members who have been selected to 'look after the mapping' have little or no field experience.

The first section briefly outlines the three distinct phases of an expedition and indicates how all members of the team can contribute to the success of the survey. The next section lists and describes readily available survey instruments\* and their range of applicability. A short section gives advice on all the various kinds of information that must be recorded in the expedition note books. The next, and most important and detailed section, is concerned with the various field techniques that may be usefully employed by an expedition, together with a recommended style of recording data in the expedition log books for the individual survey methods employed. This section will emphasize the *plane tabling* techniques of mapping. Various types of terrain are considered and some special hints for unusual circumstances presented; also a bibliography is provided for further reading.

## THE THREE PHASES OF AN EXPEDITION

An expedition has three distinct phases, all of which are important to the production of a map. The first phase concerns the pre-expedition period given to planning, acquiring knowledge of survey methods and instruments, and finally gaining field experience under simulated conditions. The second phase relates to the means by which you can put the techniques now learnt to use in an efficient and rapid manner during the course of the expedition. The last phase concerns the post-expedition

\* The Royal Geographical Society will loan equipment to approved expeditions. Other sources of equipment are Universities and Polytechnic Institutes. The Appendix lists the equipment currently available to RGS-approved expeditions.

work necessary to produce a map fit for publication, which may entail the use of computers and drawing office facilities.

All members of the expedition should be fully aware of the extent and consequences of these three phases if a satisfactory map is to be drawn by the surveyor. Hence all members of the expedition should read at least the first part of this paper; by so doing, they will appreciate the difficulties of the surveyor, and, during the crucial early days of the expedition, give helpful suggestions, constructive criticism and possibly provide manual and knowledgeable assistance, thereby helping to develop a cooperative spirit as well as a comprehensive map.

### *Phase one: pre-expedition planning*

Preparatory studies are essential and the quality and quantity of your expedition work will be based on your pre-expedition efforts. Fortunately the work involved is not of a highly academic nature but a skilled technique, developed through extensive practice, is necessary, as is great care in tabulating all the data. The first phase should cover the following four issues.

*A working knowledge of all the instruments to be used.*—All survey instruments are adequately described in several textbooks and these, or the manufacturers' leaflets, should be read at the same time that the instrument is examined and its accuracy checked. Details of the manufacturer, the model number, scales, range of applicability, likely errors, etc., should be recorded in an expedition note book at this stage. Take great care of all instruments at all times and arrange adequate insurance cover for damage or loss.

*A pilot project.*—There are several excellent outdoor training centres in the UK (for example, Brathay at Ambleside, Plas-y-Brenin at Capel Curig) which could be the base for a pre-expedition field course. Such a course is of considerable value for gaining experience in the range and rapid manipulation of your instruments; for trying all the individual and various amalgamations of the mapping techniques outlined in this paper; for simulating the terrain and, by artificial means if necessary, the environment in which you will work during the course of your expedition. For example, you should not go to the Himalaya without first having had some practice in turning the various theodolite screws whilst wearing two or three pairs of gloves.

Maps drawn during such practice can later be checked with the relevant Ordnance Survey sheets. Should an expedition member decide that, in all probability, he will never achieve the required drawing skills or speed, he should ask to be withdrawn from this task and another man selected before it is too late. Early acquisition of mapping skills is an essential prerequisite for future success. Although no more than seven to ten consecutive days may be possible for such preliminary training, some weekends and evening hours spent in practice prior to the pilot project will provide additional, but not alternative, rewards.

*Collecting reference data.*—The area to be visited during the expedition may have been either visited on the ground or examined from the air by other explorers. If not, other expeditions will have either (a) explored nearby territory; or (b), carried out botanical, geographical, anthropological or other studies similar to those you intend; or (c), visited comparable terrain in other parts of the world. All information from these sources should be eagerly sought as early as possible and fully referenced in the expedition note book. Previous reports, journals and books by travellers to the area should be studied and interesting data, relevant to your own and other expedition projects, extracted and recorded in the expedition note book. The Map Room at the Royal Geographical Society contains a collection of expedition reports, plus an

index. Application should be made to the map curator to study these reports. References should always be listed in full at this stage to facilitate relocation and citing in your future publications. It is worth noting that the national bodies and trust funds who examine the proposals for expeditions always require an indication of your ability to study, collect, synthesise and tabulate such reference information.

If maps of any quality are available, then assistance on their location and purchase will be given by the Royal Geographical Society map room staff, or the consulate staff of either the country to be visited or the country which administers the territories. For details of possible sources of aerial photographs, the reader is referred to J. W. Wright's article (1973).<sup>\*</sup> From such sources, sketch maps should be drawn in your survey log book and possible survey control points assessed for future use, as well as noting any previously established control points, especially trig stations. *The Brathay Exploration Group's handbook for expeditions: a planning guide* should also be read by all members of the expedition who have responsibilities for planning any aspects of the expedition's work.

*Interviews.*—Letters seeking interviews with experienced survey staff at nearby Universities or Polytechnics should be written as soon as possible. Most instructors will give you the advice you need and their help will greatly add to the quality and extent of your work. Good tuition may be found in departments of geography, geology and engineering and, with luck, they may have a short field course you can attend. Survey staff may also be willing to help you to analyse aerial photographs stereoscopically. Other interviews should be sought with persons who have travelled over the same sort of country as that which you intend to visit: one week before leaving the UK is too late to discover that you will need a helicopter to move bulky survey kit over a glacial river which has a maximum and dangerous discharge just at the time you arrive on the scene.

#### *Phase two: the period of the expedition*

This phase should begin with confidence in your ability, based on the pilot project experience, to draw an accurate and detailed map. However, do not be in a great hurry to start your mapping. Three issues have to be decided before mapping can begin, and they have to be carefully considered. They are: first, preliminary examination of the area in which the initial major survey-control points are to be established; second, a detailed assessment of the whole area, which will involve the surveyor visiting several future survey stations and taking copious notes; and third, the siting of a base line from which the map can begin. The few hours or days wisely spent on these issues prior to mapping should be thought of as 'gained', rather than 'lost', time.

*A preliminary examination.*—First decide where to begin the map. For example, it is always better to start work at the top of a slope and work downhill; better initially to have a wide vista, rather than a narrow one; better to start at the zone of predominant interest and then extend the map to areas of less importance; better initially to assess the size of your zone and, hence, map scales; better to know the probable sequence of visits to the major control stations before putting pencil to paper. It is unlikely that all the optimum initial conditions can be achieved and a compromise will have to be made. However, it is not essential that a start be made at a trig point or survey station of a previous expedition. Your map could be joined to older maps during phase three of the expedition. It should be noted that one most important attribute of a surveyor is to allow for flexibility of actions, since changing one's mind may cause less lost time than dogmatically insisting on rigid schedules

<sup>\*</sup> References are listed on p. 50.

or ill-conceived plans; however, once a plan of action is decided, always tell the leader your intentions.

*A possible plan of action.*—It is suggested that if the area to be mapped is large (i.e., involving stations that are separated by hours of traversing, rather than minutes), then several members of the expedition should be asked to assist during this crucial planning stage and be despatched to likely major control points, with binoculars if possible, to locate safe, adequate and well-conditioned survey stations. Each assistant should note where other assistants have gone, what other possible stations inside the zone he can see, and any other sites suitable for a future extension of the map. Furthermore, each member should make a sketch of the view he sees, note the time it took to reach the station, and possibly build a platform, and plant or paint a survey marker so that it is readily discernible from other stations.

Thus, at the end of the first day, each assistant will be able to report important facts to the surveyor. For example, with reference to Figure 1, the report of Tom (Station 5) may read as follows:

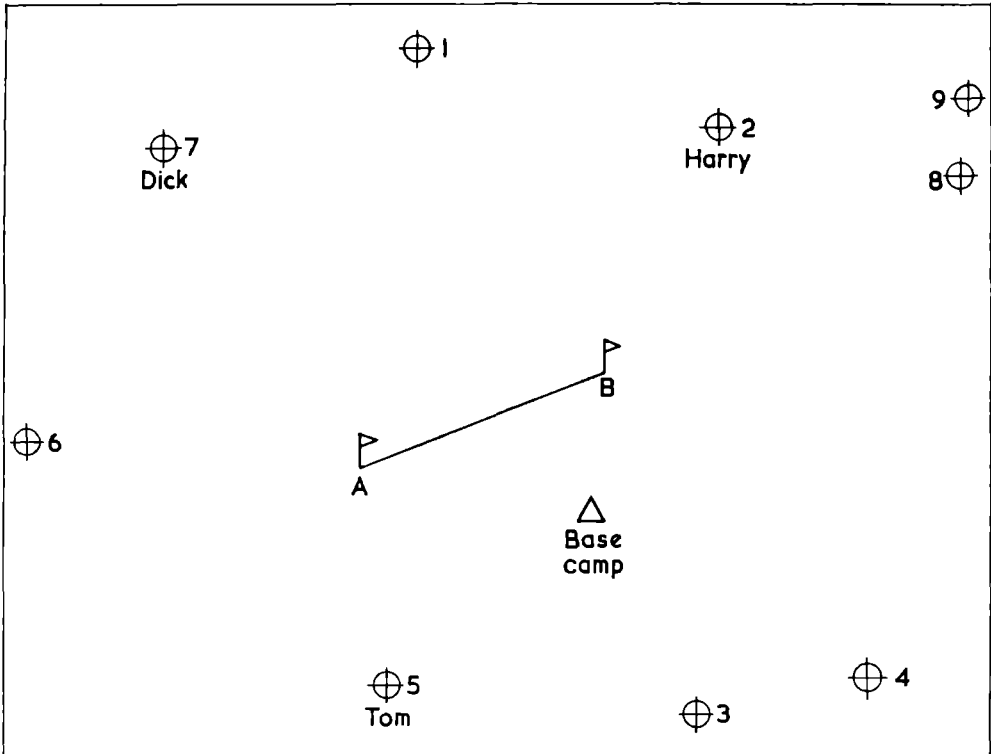

*Fig. 1. A possible major control scheme*

I could see both ends of the possible base line AB, but not the base camp. However, the sites visited by Dick (7) and Harry (2) were both visible, as were points 1 and 4 but not 3. From my view (see my sketch attached) I am confident that proposed future station 6 will be visible but not 9; however, the insignificant feature 8, clearly discernible from 5, could probably be seen by both Dick and Harry.

Note also the following hints.

- (i) Set the base line in the centre of the area of interest.
- (ii) A large number of approximately  $60^\circ$  triangles should occur on the map—a highly desirable feature for the triangulation of the zone.

- (iii) There is no need to send an assistant to what will obviously be a superb future station, say No. 4, since it is on a hillock overlooking all features.
- (iv) Line 4-7 will probably become the master base line when the major control is finalized, since it is one of the greatest distances on the map and bisects AB—two constructional features that minimize errors in length determination of all the derived lines between stations.

The first issue is now decided; that is, whereabouts the map should be started and the probable major control stations.

*A detailed assessment of the major control.*—With assistance and information of the type supplied by Tom and other colleagues, the major ground control can now be positioned on a map within a few days, but it is advisable that the principal surveyor himself should first visit the majority of the survey stations for the following reasons: (i) to locate and assess the stability of the exact future position of his theodolite or plane table; (ii) to evaluate from the information now available, plus his own experience, which other desirable features and stations can be observed, with the aid of binoculars, at each particular station; (iii) to note in his own log book the possible extension zones and in what sequence they should be mapped; (iv) to take a series of Polaroid camera shots for immediate cross-reference; and (v) to note in the log book, while traversing the ground between stations, the kind of detail that will need to be mapped and its degree of importance. When the reconnaissance of control points is completed, the surveyor can begin with measurement of the base line AB (see p. 23, 'Setting out the base line').

During the entire course of the expedition, the surveyor will stop periodically during his travelling, look around, and record the new details he can see and the old details he can recognize. Especially important is the recording of the location of places from which major control points can no longer be sighted, since these places may be difficult to map. A wise surveyor will keep a duplicate set of data tabulated in the expedition note book which is safely stored at base camp and/or in a companion's log book. A duplicate map should also be kept up to date and stored at base camp. From such commonsense beginnings, a useful result should be achieved.

### *Phase three: post-expedition*

A prudent leader and a knowledgeable surveyor know that the best results will be published only if two weeks are set aside on returning home for the sole purpose of finalizing all the survey work. While many factors are still in one's mind during this early post-expedition period, they will be forgotten two months later and, by that time, it will be too late to take corrective action or to debate or check doubtful data. In this period log books should be checked, indexed and safely stored; computer programs (if not composed during phase one) must be written, checked and used to evaluate your readings; all part-maps, graphs and tables must be assembled, documented and stored; and all instruments be cleaned, checked, repacked and returned to the owners, together with notes giving details of their possibly faulty operation and suggested repairs. All those who participated in the survey work should be available for discussion during this period, possibly completing the reports for which they were individually responsible. All survey films should be checked, labelled, catalogued, packed and given to a nominated custodian for safe keeping. Finally, the completed and inked map should be duplicated and sent out to expedition sponsors as an indication of your ability to produce quickly the keenly-awaited expedition report.

## SURVEY INSTRUMENTS

This section provides a list of instruments that are used in mapping and a brief description of each item. In a four-man expedition, only one person may be responsible for surveying but he may require all the following equipment, some key items of which should be duplicated in case of accidental damage during the expedition. The extent of duplication and the classification of equipment into categories, such as (i) essential; (ii) highly desirable; (iii) possibly useful; and (iv) duplicate, will be a matter of discussion between the expedition and its advisors. Factors such as the priority of the survey work, the degree of accuracy required, the type and locality of the terrain to be mapped and the duration of the expedition will all affect the final choice of instruments, as will the means by which the equipment will be safely transported to the expedition base. All items of survey equipment taken on the project should be insured against damage or loss and be inside protective covers.

### *Survey equipment*

Plane table and cover	Record books
Tripod	Erasers†
Telescopic alidade and box	Pencils: 3H, 2H and HB†
Trough compass*	Razor blades†
Special drawing paper	Glass paper blocks†
Tracing paper	Electronic calculators or logarithm and trigonometrical tables
Scale rules†	Polaroid camera and films
Scotch tape†	Small scissors*
Spirit level†	Paint and brushes
Quickset level and tripod*	Adjustable set square
Levelling staff	Dividers†
Compass	Compasses, with extension bar†
Theodolite and box	Metal files
Theodolite tripod	360° protractor (large)
Subtense bar*	Marker flags
Range finder*	Binoculars
Aneroid barometer	Ink and pen
Measuring tape (approx. 50 m)	Survey notes and pamphlets
Plastic tubes	

Items marked † may be safely stored in the alidade box. Items marked \* may not be essential if other items are taken: see later discussion.

### *The plane table and its cover*

Various sizes are available. Select only one size but take two tables. Do not use tables that are full of drawing-pin holes. Check that the table is robust and not damaged in any way. Check the tripod attachment-screw thread. It is most important to check that the table is perfectly flat over its entire area. Make special plastic covers if the table and paper may be subjected to very damp conditions, but ensure that all plastic covers can breathe by inserting small holes along their edges. Many of the above points apply equally to other items of equipment, so please read them again.



### *Tripods*

Take at least two tripods. If possible make an interchangeable head so that the plane table, or the theodolite tripod, may take all other instruments. Check extendible legs of any lightweight tripod, also the leg-clamps and screws, and the facing plate on which the instrument should seat perfectly. Examine the tripod feet tips for weakness. Look for faults in general, and effect repairs or exchange for better models before your pilot project.

### *The telescopic alidade*

The alidade is a sighting device used with a plane table. It may be an ordinary boxwood type containing a slit and thin wire (or hair) sighting line, or it may be telescopic. The latter type will be discussed here since it has far more details of construction and operation which must be understood, although the basic principles remain identical. The telescopic instrument is suitable for tacheometric (distance measurement) work and for calculating elevations. The adjustable parallel beam edge, along which pencil rays are drawn, should be checked for accuracy by drawing one pencil ray along its edge on to a sheet of paper and then turning the instrument through  $180^\circ$  before drawing a second ray, which should be exactly parallel to the first ray over its entire length. The underside of the base plate should also be checked for flatness.

As the telescope is the major feature of this and other instruments, it is worth describing it in some detail. When looking through the eyepiece, the cross-hairs (C) (see Fig. 2) indicate the horizontal line of sight (collimation) and the vertical plane.

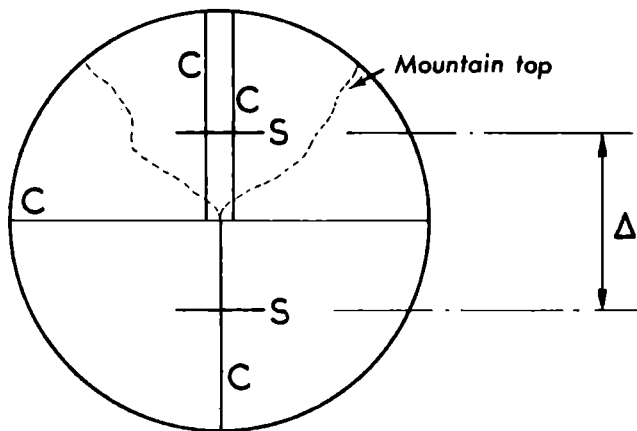

Fig. 2. *The view through a telescope*

The eyepiece cylinder should be rotated by its screw thread until the cross-hairs are brought into sharp focus. The object to be examined is then itself brought into focus by turning the main telescope body screw. The view (a mountain top in Fig. 2), as seen through the telescope, is upside down but practice trains the brain to compensate this effect automatically. Before taking readings of the sighting, the horizontal plane of the instrument should first be set by centralizing the bubble of the spirit-level attached to the telescope body and then rechecking the sighting. The best posture for viewing through the telescope is shown in Plate I. With a little practice this position is not uncomfortable and causes a minimum of interference

with the apparatus. After recording a reading in the log book, the view through the telescope should always be checked to make certain that neither the tripod, the table, nor the instrument has moved. With reference to Figure 2, the upper cross-hair may be split to facilitate precise location of the object. Two horizontal stadia-hairs (S) may also be included in the eyepiece and are employed for tacheometric work which will be discussed later. Important points to remember are: never look through the telescope into the sun; protect the instrument from dust and knocks; and replace the lens cap when not in use.

Two spirit levels are mounted at right angles to each other on the alidade and so, in theory, there is no need to have the plane table perfectly horizontal. However, the amount of adjustment of the telescope for each reading will be reduced, and the station completed more quickly, if the table is set level initially. Vertical readings of any object are recorded in a manner to be discussed later. A final, necessary feature of the instrument is the parallel and movable beam of the base plate, which permits the drawing of a ray of an observed object exactly through the required reference point on the plane table without having to move the whole instrument. Thus the object is approximately located via the primary sighting device when the base edge of the alidade is a short distance removed from the current reference position on the map. The object is then exactly located in the telescope and the parallel beam carefully and slowly moved so that a pencil ray drawn along its edge passes through the reference point. Fingers should be lightly clamping the beam while the ray is drawn. Finally, the sighting of the object is checked before the alidade is lifted off the table, rotated, and placed back on to the table in an approximate position to sight the next objective.

#### *Trough compass*

This long, narrow container holds a needle which, when pointing to zero, indicates the local magnetic meridian. This direction should always be drawn on your map since it assists the setting up of the table, especially in poor visibility. Note that magnetic north may change slightly over the area covered by your map due to variations in the local magnetic field. Keep magnetic materials away from the compass when ascertaining the relative orientation of the magnetic meridian to the plane table map.

#### *Drawing and tracing paper*

Drawing paper which will not become distorted and which is suitable for use in strong sunshine, rain or snow should be used, for example, Astrafoil or Kodatrace. Several sheets of the paper should be cut to a size slightly less than that of the plane table, leaving a 4 to 5 mm clearance on all sides, and having rounded corners to minimize fraying and tearing. The majority of these sheets can be stored on the duplicate table and kept inside the table covers at base camp. All the paper leaves should be secured with only one cross-piece of scotch tape at each corner of the top sheet, and the tape should be carried well over on to the underside of the board. This minimum build-up of the corner height of the table will not affect the level of the table, but care should be exercised not to place the alidade edge on the corner pieces of tape, nor to allow pieces of grit to penetrate between the individual leaves of paper. Ample spare sheets of paper should be safely stored at base camp. One roll of scotch tape, approximately 25 mm wide, will be sufficient for survey and other projects, and a limited length may be stuck inside the alidade box or on the underside of the table for ready use. Tape should always be used in preference to drawing pins.

A similar quantity of tracing paper sheets of a size identical to the special drawing paper should also be taken. Advice on quality can be obtained either from drawing office equipment suppliers or draughtsmen in local drawing offices. A reliable brand in regular use is 'Gateway': note that tracing paper can change its dimensions in variable climates, so mark off exact distances, say 300 mm, in two mutually perpendicular directions on the paper, so that it can be checked for any distortion at the time of transferring detail, which may be several weeks later.

### *Scale rules*

Metric scale rules (model B371) are required for measuring and marking off distances on the map. Invest in two of these accurately calibrated wooden rulers since they do not transfer grime on to drawing sheets, as do metal rules. Furthermore, wooden scales are best when used in combination with dividers. When setting off distances on the map or the dividers, use different origins on the rule in order to minimize obliterations of the scale. The edges of these rules are levelled to facilitate easy transfer of readings to and from the map.

### *Spirit-level*

It is best to take a spirit-level to facilitate the setting up of tripods and plane tables and to check periodically and rapidly the overall level of the plane table. Levels should be approximately 20 cm long.

### *Quickset level*

This instrument is used for rapid levelling and traversing. An approximate horizontal level is achieved by manipulating the three screws in the base, an operation described later for the theodolite, but, before each sighting of an object, the telescope body is separately and precisely levelled. The cumulative error over a levelling distance of 1 km should be less than 20 mm. With practice, one should be able to develop scale-reading ability to the nearest 0.001 m.

### *Levelling staff*

The most popular kind is the extendible type; it is marked off in centimetre increments which are recorded as 0.01 m intervals in the log book. The staff scale is seen upside down in the telescope, so learn to distinguish the 6 and the 9. Examine the staff and its scales closely before use. The assistant should place the staff on firm ground and watch the observer at the telescope who will inform him if the staff is leaning sideways. When readings are being taken, the assistant should slowly rock the staff slightly backwards and forwards through the vertical plane, and the surveyor should record the smallest reading observed as this corresponds with the vertical position of the staff.

### *The compass*

Modern models are lightweight and are now replacing the heavy prismatic compass for sketch map work. The Suunto model has its 0.5° graduated circular disc encased in a liquid that reduces oscillations and so facilitates rapid readings to an accuracy of approximately 15 minutes of arc. A single view-hole permits both a sighting of the object and the scale which records the angle relative to the magnetic meridian. Initial maps that are sketched while travelling can be modified later by the method of resectioning (see p. 33). Remember that these instruments must not be used in the vicinity of any iron objects which one may have stored in one's pockets.

### *The theodolite*

This item is the most important of all the survey instruments. It can measure vertical and horizontal angles and can be used for tacheometric work. It is an accurate and delicate instrument; its use requires much care and, for the inexperienced, much practice. The model described here can record to five seconds of arc, although more accurate instruments are available. The theodolite fits into its box in a particular way; for example, three painted yellow dots may be uppermost, one dot on the main body, one on the horizontal circle, and one on the base plate, and these three dots will be in line with one another. The main features of the microptic theodolite are shown in Plate II, but the manufacturer's leaflet for your particular model should be read before using the instrument.

*Setting-up procedure.*—The instrument looks complex, but in reality it is a simple tool although it has to be used frequently in order to achieve familiarity. After much practice, a high degree of accuracy can be attained. Before removing the instrument from its box, use clamps F and G to lock the instrument (see Plate II), and then carefully place the theodolite on its tripod and secure it with the tripod attachment-screw or other clamping device. Make certain the theodolite is correctly seated on the tripod. The levelling technique is now described and this applies to all similar three screw-legged instruments. Unclamp G and swing the in-built spirit-level A of the instrument parallel to the line joining two screw-legs B–B. Rotate the screws of the two legs in opposite directions so that one leg is raised and the other lowered, until the bubble indicates a level has been achieved. Next rotate the still-unclamped body C until the spirit-level has moved through  $90^\circ$  and then adjust the third screw-leg, until the bubble indicates a horizontal level. The instrument should then be level. Check this by noting the bubble's position at all angles of rotation of the body. With practice this operation can be completed within a few seconds.

When putting the instrument back into its case, make certain that (i) the travel of the screw-legs is approximately half-way so as to forestall difficulties of levelling at the next station, and (ii) the three dots are uppermost and held in line by locking clamps F and G. When the instrument is firmly seated back in its box, unclamp F and G so as to prevent unnecessary jarring of the individual sections of the instrument during transit.

For accurate survey over short distances, it is necessary to place the theodolite over a specific ground point; this is achieved by using a plumb bob and line attached to the bottom of the instrument and which is suspended between the tripod legs. In many models an optical plummet D is provided plus a centring clamp E.

*To take readings.*—The horizontal circle protractor can be locked either to the base plate or the upper body by the clamps F and G, respectively. When clamped, the horizontal circle can still be moved relatively and slightly to the upper and lower plates by adjusting screws called tangent screws, one screw H for the upper plate and one screw J for the lower plate. The position and feel of all these differently constructed knobs will be learned with practice.

Let us now assume that the theodolite is levelled. Observe through the eyepiece K the readings of both the vertical and the horizontal scales which have a common micrometer scale (see Fig. 3). The two examples shown in Figure 3 differ only in the units of the scales. Figure 3a shows the scales divided into the conventional, sexagesimal divisions of degrees ( $^\circ$ ), minutes ( $'$ ) and seconds ( $''$ ), while Figure 3b shows decimal divisions. The latter units are more suitable for immediate calculations on an electronic calculator. To facilitate readings of these scales, the eyepiece K can be rotated and more or less light can enter the system by adjusting the reflecting mirror L. Practise reading both the main and the micrometer scales. Only one of

the angles, horizontal or vertical, can be read at any one time. In order to read either the vertical or the horizontal scale through the eyepiece, it is first necessary to set the major scale exactly to a 0, 20 or 40 minute division line of that scale by turning the micrometer knob M until, for example, the major horizontal scale reads  $23^{\circ} 20' 00''$  in degrees, minutes and seconds (see Fig. 3a). The difference due to the movement of the micrometer,  $00^{\circ} 12' 25''$ , can then be read off and mentally added to the first reading. It is easy to make mistakes, so acquire much practice with recording such data. In order to read the vertical scale, it is necessary to adjust the micrometer once again until that major scale pointer coincides with an exact division on that scale (see Fig. 3b). It will be noted in Figures 3a and 3b that the scale pointers do not coincide simultaneously with a divisional marker on both major scales; hence the necessity to adjust the micrometer when transferring from a vertical to a horizontal reading, and vice-versa.

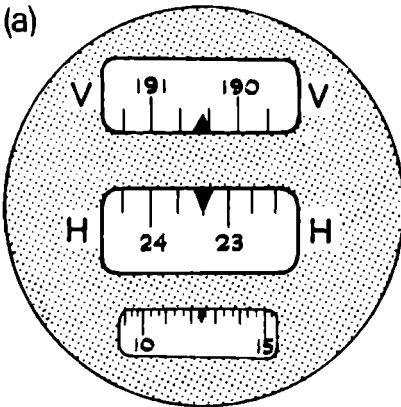

Example of horizontal  
circle reading  
(Sexagesimal)

Circle	$23^{\circ} 20' 00''$
Micrometer	$12' 25''$
	<u><math>23^{\circ} 32' 25''</math></u>

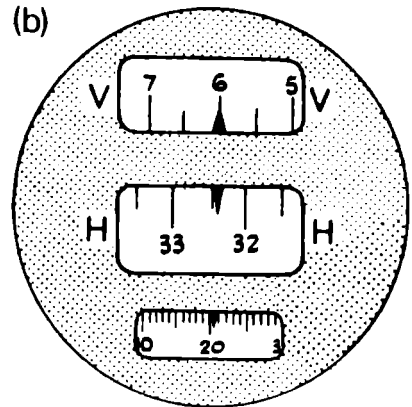

Example of  
vertical reading  
(Centesimal)

Circle	$6.00g$
Micrometer	$0.205$
	<u><math>6.205g</math></u>

Fig. 3. Microptic scales of a theodolite

When taking the initial readings, first clamp the horizontal circle to the base plate by using the lower clamp F. Swing the upper body freely until the horizontal reading is approximately zero. Clamp the upper plate with knob G. Use the micrometer knob M to set the micrometer reading in the eyepiece to zero. Use the upper adjustment (tangent-) screw H until the reading is exactly  $00^{\circ} 00' 00''$ . Unclamp the lower plate, knob F, and swing the body round until the first objective is seen through the telescope N which carries a simple primary sighting device P, the telescope cross-hairs having previously been sharply focused. Clamp the lower plate, knob F, and use the lower tangent-screw J until the objective is exactly centred in the telescope. The lower knobs, F and J, need never be adjusted a second time while at a particular station. With the aid of the adjustable mirror W, use the altitude tangent-screw T to adjust the telescope bubble V to zero when centring the objective in the telescope. To determine the correct elevation of the objective, clamp the telescope with knob R and adjust the elevation with the telescope tangent-screw S until the objective is at the junction of the cross-hairs. Check the level once

again. Read the vertical scale. The horizontal scale should still be at zero if the instrument was levelled correctly initially; however, there is no necessity to have the initial horizontal reading exactly at zero, and it is only suggested here because it simplifies calculations by the surveyor, or assistant at the survey station, and hence reduces the possibility of errors.

Record all data in your log book. Before releasing the upper clamp, check the telescope sighting once more and then swing the instrument in one direction only (clockwise) towards the next and all future objectives. Once a round of readings has begun the basic sequence of operations is: sight, clamp, adjust, read, record, resight and check. If the telescope eyepiece is to the left of the circle eyepiece then these readings are termed face left (FL) data. A round of readings is only completed when the first objective is resighted and re-recorded. At this stage, the telescope is pivoted through  $180^\circ$  and a sequence of face right (FR) readings taken with the telescope once more tracing an arc, but in the opposite direction. A simple rule is FL, swing right; FR, swing left. Remember to resight on the first objective at the termination of this round of readings also.

The major difficulty in setting up a theodolite is the problem of attaining a rigid, as well as an unobtrusive tripod. This may be awkward on soft earth or river mud. Just before taking readings, give the instrument a slight twist. The assembly should automatically swing back to the original position of the telescope, so indicating no permanent deflection. Then walk round the tripod and theodolite several times so that, subconsciously, you are aware of the position of the tripod legs with respect to the vista. On soft ground, three niched, circular, base-boards or jerry cans may help resist sinking of the tripod legs. Finally, the stability of the instrument should be checked frequently by periodically resighting on to the initial station.

Practice using the instrument by checking all the angles on your local tennis court and traversing round local buildings or park land.

#### *The subtense bar*

This is a long rigid horizontal bar of known and exact length  $H$ , and permits a relatively high degree of accuracy for determining the distance  $CD$  of Figure 4. The

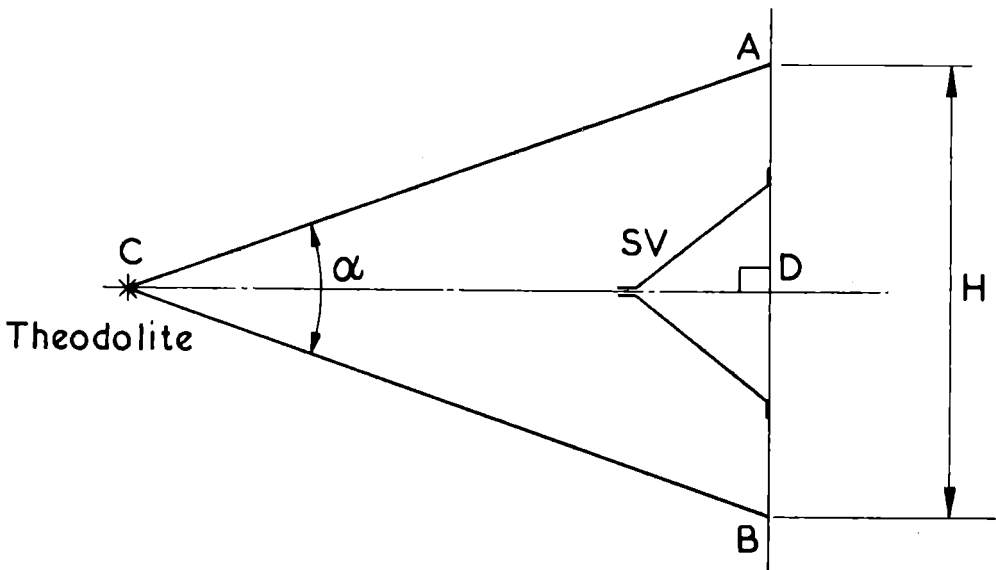

Fig. 4. Determination of distance from a theodolite and a subtense bar



theodolite at C is set on A and the horizontal angle read. The upper plate of the theodolite is then unclamped and the instrument set on B, clamped, and the horizontal reading taken for B, after the necessary adjustment with the upper tangent-screw. Now unclamp the lower plate, turn back to sight A, clamp, and adjust with the lower tangent-screw. Unclamp the upper plate again and swing back to B. Repeat the above procedure about ten times. The incremental increase of the angle  $\alpha$  should be constant but the averaging procedure should give the required high accuracy. Expeditions often use this technique to determine distances by manufacturing their own 'subtense bars' in the field from bamboo poles, plastic tubes etc., but it is best frequently to check such instruments. It is possible to use the levelling staff in a horizontal position as a subtense bar, but a tripod attachment with a rigid clamping device is required. The distance CD, from the theodolite to the subtense bar, is given by

$$0.5H \cot \frac{\alpha}{2} \quad \dots \text{equation 1}$$

When measuring short distances, it is necessary that the subtense bar be set such that angle ADC is  $90^\circ$ . This can be achieved by having a sighting vane SV rigidly attached to the subtense bar. The theodolite then lines up the vane sight with the centre of the subtense bar, thus ensuring that the bar is correctly positioned.

*The range finder*

This instrument is also used to determine distances and is most valuable for route traversing and detailed plane tabling since the surveyor using it requires no assistance from other members of the expedition. Errors are approximately 0.5 per cent over a distance of 2000 m (i.e.  $\pm 10$  m) and the instrument can be used with confidence up to 10 000 m.

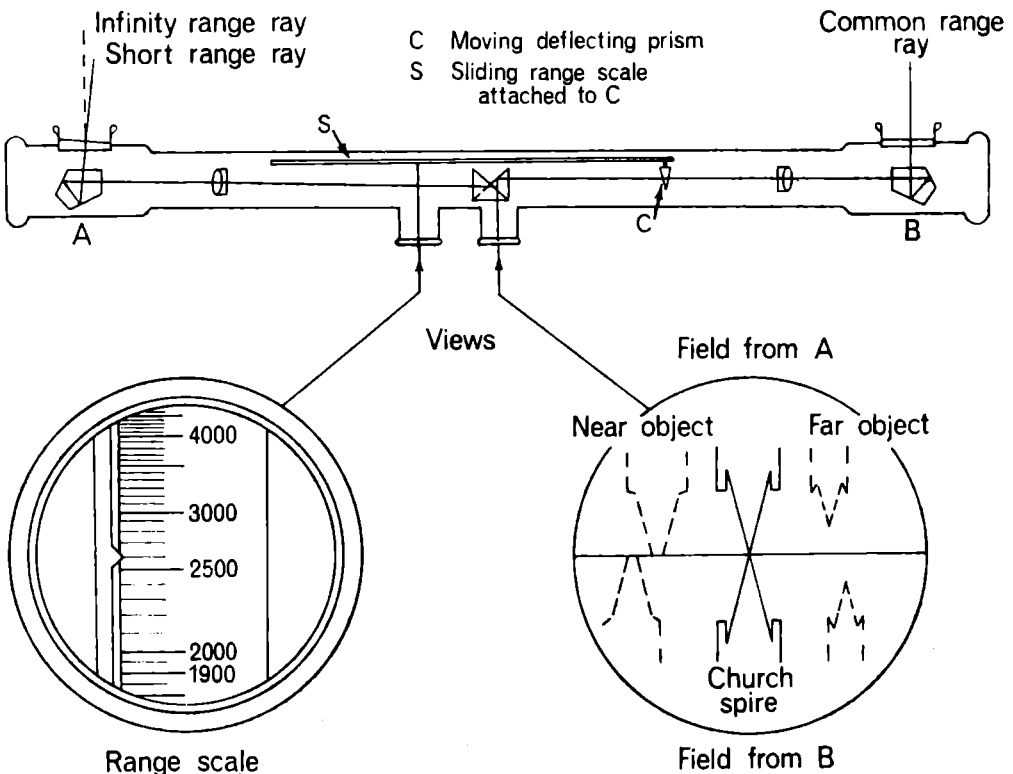

Fig. 5. The range finder

Two instrument objectives, A and B of Figure 5, are fixed a precise distance apart, say 1 m. The two views of the one distant subject are joined, but split, by a system of prisms and compared in one eyepiece. A fine micrometer-screw rotates one of the prisms and so enables the views to become coincident. The graduated scale of distance of the micrometer can be read directly in the other eyepiece. The scale is non-linear and may be graduated in 5 m increments for distances between 250 and 1000 m, but 25 m increments from 1500 to 2000 m. Beyond the 10 000 m range, inaccuracies may become unacceptable. This instrument, however, often provides readings whose errors are too small to observe on a plane table, gives rapid and direct results, and can be carried in one hand; so give it the respect and care it deserves.

### *Aneroid barometer*

This instrument is used to determine the relative differences in altitude above a reference level and not the precise altitude; hence it is best to determine the exact datum height by triangulation from known trig points. A change in altitude results in a change both in temperature and in atmospheric pressure, but it is only this last parameter which is measured by an aneroid barometer whose scale is graduated in metre (or feet) units. Thus, at the same time as reading the instrument, the local temperature should also be recorded in order to correct for the effect of temperature on pressure. The instrument is useful for contour mapping and should be calibrated before the expedition, possibly at the National Physical Laboratory. A range of scales up to 6000 m or higher is available. The instrument should always be read in the same position, i.e., with the scale face vertical, and great care should be taken in transporting it. Do not allow it to be jostled in your pockets. (Hamilton *et al.*, 1957.)

### *Measuring tapes*

The most simple but necessary item. A 50 m tape should be adequate. Examine the tape before use and determine the exact zero mark with respect to the terminal link which is usually made of brass and may be loose—so keep it taut when measuring. Modern, lightweight tapes are available but any tape should be checked before and after the expedition to determine its accuracy and calibration with reference to the environment of the expedition. Metal tapes of low coefficient of thermal expansion, although heavier than fibre tapes, may be necessary in order to achieve the required accuracy in mapping.

### *Poles*

A selection of plastic tubes should be taken which can serve as ranging poles, subtense bars and flag poles. They are light, slightly deformable and do not easily break. They can serve other purposes, such as a surveyor's flag rod, tent pole replacements, sledge runners, makeshift splints, or snow probes, to name a few.

### *Log books*

Each member should have a record book in which to insert data which will assist the surveyor. Other than having a waterproof plastic cover and adequate pages, it needs no further description except that it must not be of a loose-leaf variety. Your selection will be made after reading the typical data layouts shown in this paper; in addition keep two spare books available at base camp, one of which should contain mm-squared graph paper.

### *Erasers*

Two duplex erasers should be taken, with one soft side for removing HB lead and one hard side for removing both 2H lead and any dirt marks. There should be no need to remove the very faint rays drawn with the 3H pencil. Keep erasers in the alidade box in thin plastic covers so as to keep them clean. A good surveyor seldom has to use an eraser but any eraser particles should be lightly brushed off the table with the *back* of the fingers and hand so avoiding deposition of perspiration on to the drawing.

### *Pencils*

Keep 3H, 2H and HB pencils, two of each kind, in the alidade box. Do not use harder pencils than 3H for drawing faint rays. Regularly re-sharpen the *chisel* points of pencils, for example, after six full, board-length rays. Sharpen the point at the correct end of the pencil, i.e., at the end removed from the pencil grade indication marker. Conical points for H and HB leads are required since these are used for writing symbols and sketching outlines rather than drawing rays. The 2H pencils are suitable for inserting the finalized location of intersected points that have been clearly and correctly identified.

### *Razor blades*

A packet of six should be kept at base camp but the one kept in the alidade box should have its edges protected by scotch tape. Do not use the blade to cut the pencil lead, only the pencil wood.

### *Glass paper blocks*

Two blocks should be kept at base but one sheet, approximately 20 mm × 40 mm, should be stuck to each of the tripod legs with tape to facilitate frequent sharpening of the chisel points. If the legs rock on sharpening then the tripod is not as secure as it should be.

### *Electronic calculators or logarithm tables*

Seven-figure log and trigonometrical tables, or better still, pocket electronic calculators, are essential for accurately determining distances and heights for your survey. Advice on calculators is given by W. D. Rushworth (1975). Learn to use the full range of the electronic instrument as early as possible, even before the training project, and remember to take ample replacement batteries in case you fail to switch off the instrument at the end of each calculation. Get another member of your expedition to check all your calculations *independently* and do not tell him your answer before he concludes his own checks.

### *Polaroid camera and films*

Such items are desirable pieces of modern survey equipment. Immediate records of views from stations saves all sketching in the log book other than essential details of a view. Important features can be given names, numbers or letter symbols which should be recorded on the back of the print. This will eliminate confusion of notation with details of the view from other stations, since previous and similarly documented photographs will always be available in your pocket. Also, information on the film prints can be readily and immediately appreciated by other members back at base; extension map zones can be studied at leisure before survey camps are transferred to new locations; and greater detail can be subtracted from the

prints during phase three of the expedition and compared with detail seen on random photographs taken by other members of the group. Take the precaution of talking to someone who has recently used this modern facility on a survey expedition.

### *Small scissors*

Since the medical man will undoubtedly carry a pair of scissors, this item is not essential to the survey kit. Other than the aforementioned razor blades, it is likely that someone else on the expedition will be carrying a sharp blade such as a pocket knife. Remember that it is better to cut up as many drawing and tracing paper sheets as possible and to attach them to the plane tables before leaving home.

### *Paints and brushes*

Where possible, paint each survey station with a bright colour; orange is recommended. A paint that best resists the relevant climatic conditions will be recommended by manufacturers. Not only do you wish to locate painted markers, probably over a period of weeks and over long distances, through a theodolite but subsequent expeditions may also wish to use your markers, so paint accordingly (e.g. 1 m diameter circles and two coats of paint for markers on rock walls of a mountainside). Take two 8 cm wide brushes and thick plastic-bag containers to avoid contamination of the paint with other items.

### *Set squares*

Invest in one large adjustable, transparent set square with bevelled edges, rather than a number of fixed shape set squares. This instrument simplifies the transfer of data from one underneath sheet to a top cover tracing sheet (see Fig. 6), this latter sheet possibly being to a reduced scale and displaced relative to the original drawing in order to accommodate extension surveys.

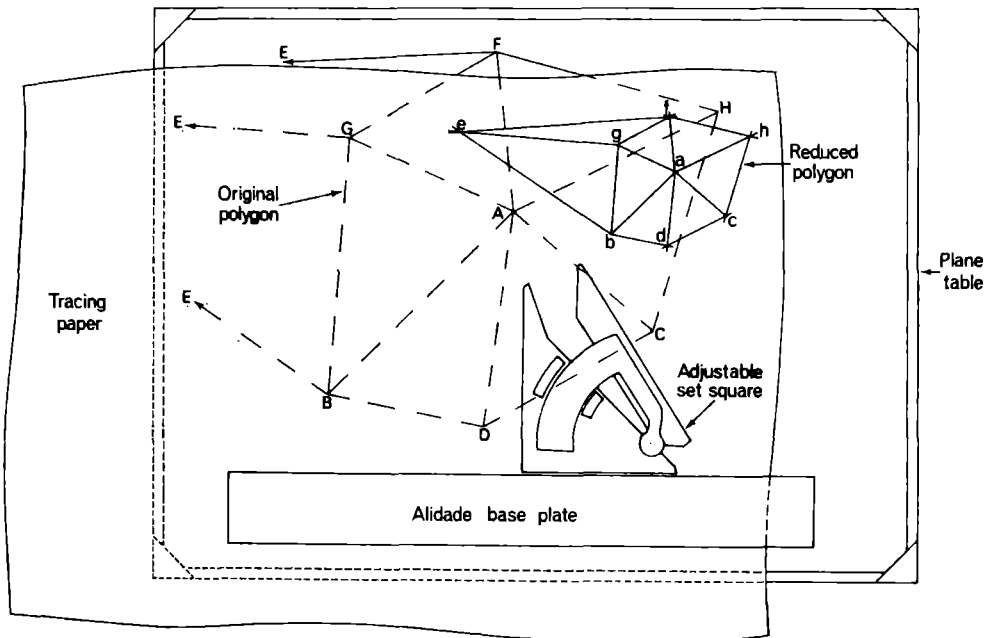

*Fig. 6. Transfer of details by an adjustable set square*

Figure 6 shows the original drawing paper attached to the plane table with corner pieces of drafting tape. The initial major control ABCDFGH is now too large a scale and does not permit location of point E. A piece of tracing paper is placed over the top of the original (hence the pecked lines on the diagram) and is held down by both the weight of the alidade and some additional pieces of drafting tape (not shown). The alidade base is kept rigid in one position while the adjustable set square slides along the alidade edge, thereby transferring lines to the tracing paper; these are parallel to the original lines, giving the reduced polygon *abcdfgh*. It will be noted that lines AB, AD, AC, etc. are parallel to the new lines *ab*, *ad*, *ac*, etc. although the scale has been reduced and the initial major control zone removed to the upper right of the new sheet so as to permit extension of the map.

### *Dividers*

Having drawn a large scale grid of the major or initial control zone, you may wish to extend your map, which necessitates (a) reducing the scale and/or (b) transferring the control zone to another part of the plane table area. Metal needle-pointed dividers will facilitate this transfer to a new sheet, either directly by length transfers, or indirectly by checking the transfers via the adjustable set square technique. However, remember there is no need to push the divider needles through to the back of the plane table or scale ruler. Pin-pricks as faint as the 3H pencil rays are sufficient. When using sharp needle dividers for measuring off distances on accurately calibrated scales, always use different origins. Your local drawing office staff may be prepared to loan you dividers for your project.

### *Compasses*

A pencil compass with fine adjustment and separate extension arm should be taken to assist the transfer of details from one map to another of the same scale. The pencil lead should have a chisel point and the centring pin should not make too discernible an impression in the paper.

### *Metal files*

Two files, one very fine (a Swiss file) and the other an ordinary engineering file, should be taken. The first can be used for sharpening pencils and metal needles, whilst the second could be used for removing accident-induced burrs on survey components, e.g. tripod foot points.

### *Protractor*

A large 360° transparent protractor is an invaluable instrument in the field for transferring theodolite readings or compass bearings to plane table maps.

### *Flags*

Take two (or even three) colours. Red, blue, green are recommended but they should contrast with one another and the local scenery. Alternate colours should be used on a traverse line of fixed stakes in order to assist recognition of the stake number. Sleeves should be stitched into the flags so that they slide on to the stakes. Two 0.5 m tapes should be sewn on to each flag to help secure the flag to the plastic tubes or poles. The size of flags should be approximately 0.5 m square.

### *Additional items*

It is advisable that the surveyor carry one good pair of *binoculars*. Convince other members that it is in the interests of the expedition that they, too, should carry binoculars, but possibly only of pocket size.

Should it not be difficult to transport a small bottle of *indian ink* and fine *drawing pens*, then it will be worthwhile to do so. Only ink those details that are accurately positioned and finalized. Practise drawing with ink for a few hours prior to the expedition since it is all too easy to introduce errors through incorrect copying and to deposit stains or blots via fingers, rule edges and pens rolling on the table.

An experienced surveyor will utilize general expedition equipment to augment or replace items of survey equipment mentioned above, thereby reducing the number of items to be transported to and from home. *Painted boxes, food cans, tent pegs*, etc. can all serve as ground markers. *Saplings* can act as ranging poles and discarded *clothes* can serve as flag material.

An *umbrella* is often a necessary item of equipment since it can protect a plane table or theodolite from the weather. For example, very strong sunshine can cause one side of a theodolite to expand slightly and so alter the instrument level, leading to the recording of incorrect angles.

Keep a note book at base camp for use by any member of the expedition to record data that may be of benefit to the surveyor during phase two or phase three of the expedition. This book should also contain information gathered during phase one of the expedition.

## THE SURVEYOR'S RECORD BOOK

The surveyor's log book should contain all the survey information collected by all members, even though some of the facts were considered relatively unimportant at the time the data were recorded. All data should be recorded in a neat, logical, sequential and interpretable manner, so that another person, not associated with the expedition, could later extract the information required to draw a map. The log book will be used during all three phases of the expedition and will have separate sections dealing with:

References	Future actions
Instrument lists	Notes for the 'Survey Report'
Diary of daily events	Index and details of all survey stations
Sketches and conventions employed	and points
	Field recordings

Some of this information will also be stored in the expedition record book and may not need to be duplicated in the surveyor's log book.

### *References*

All references pertaining to the three phases of the project should be fully detailed in such a manner that the information cited can be easily retrieved. Thus books, journals, reports, aerial photograph numbers, instrument catalogues and any other reference material should be listed. As an example of how to cite references, please note the manner in which they are recorded at the end of this paper.

### *Instrument lists*

All survey items taken on the expedition, and for which the surveyor is responsible, should be listed, together with their quantity, weight, cost or loan charge, insurance cover details, serial numbers, faults, etc.



### *Diary of daily events*

Keep a concise, but precise, statement of all your actions during the three phases of the expedition; this will be of immense value later and will also assist future explorers in their planning. This diary, for example, should note the day on which map section No. 5 was drawn, or the day spent at base due to bad weather when it was possible to amalgamate map sections 1, 3 and 8 to produce map 10, thereby superseding maps 1, 3, 4, 6 and 8.

During a rapid traverse of an area, it may be possible to use a compass to determine sufficient detail subsequently to draw an accurate sketch map of the area traversed. Such compass work detail should be recorded in the 'daily' section of the log book.

### *Sketches and conventions employed*

Black and white polaroid shots will not give the detail you may require, say, of a distant peak with two pinnacle summits and so it will be necessary to sketch additional data into your book, informing the reader at a subsequent date that the left-hand cracked northern pinnacle was chosen as reference point 107 rather than the right-hand flat-topped southern spire. In general the volume of sketches should far exceed the volume of survey data tables, described later. Sketches will also be drawn of details observed whilst walking between stations, and of the position of other stations, and details viewed through the telescope from each and every other station. The art of sketching needs to be practised extensively during phase one of the expedition.

Conventions and lists of symbols employed should be inserted in your book so that you can minimize the number of words written on the plane table map.

### *Future actions*

During the progress of the expedition many issues will be raised that require actions or decisions at some future time. These need to be listed; for example:

- (a) Inform previous expedition that point 217 is now estimated to be 1307 m in height, not 1500 m.
- (b) Tell next year's expedition that the river may be forded early in the morning at a point shown in sketch 17.
- (c) Distribute immediately on arrival home a list of urgent actions pertaining to various aspects of the survey that must be done by other members of the expedition; for example, construction of computer programs; return of equipment, etc.

### *Notes for the 'Survey report'*

Always bear in mind that you will soon have to write a survey report and this report will necessarily contain several sub-sections, possibly including suggestions for improving this paper! Jot down the most probable layout of your report and possible sub-headings that come to mind during the course of the project, along with copious notes for the various chapters; these can be edited later.

### *Index and details of survey stations and points*

All map sections (i.e., different drawing sheets) should be numbered, dated and indexed in your log book. Also, keep an index of all stations, points and important details of your maps. This will ensure you will not repeat code numbers or letters

and so will be able to provide non-contradictory information at a later date. An example of such a note:

*Station 18.* Edge of northern ridge of cliff beyond lake 3. Visited 16 Sept. Approach from northern talus slope dangerous but obvious and quick. 3 hours from base camp from which magnetic bearing is 175.5°E. Theodolite centre 2 m in front of paint marker. Aneroid reading 1725 m.

You will note that a surveyor is busy at all times, recording data that will assist him or others to produce an excellent map during phase three of the project. Undoubtedly, however, the tables of results are the most important of all data recorded and an example of the manner in which this is done is now presented. This will assist an understanding of the techniques of mapping.

### Field recordings

Before drawing up a results table, always declare the following information: Date; time of day recording began; time taken to reach station; instruments used; visibility and weather conditions; names of members assisting. All the above data, however trivial you may think at the time of reporting, can be absolutely vital during subsequent analyses several weeks or months later. Also, record the height of the theodolite and its position relative to the survey marker.

*Typical layout of telescope readings.*—The example shown in Table I is from a set of theodolite results. Note the following:

FROM STATION D	FACE RIGHT								
	HORIZONTAL						VERTICAL		
Sighting	Reading			Difference			Reading		
	o	'	"	o	'	"	o	'	"
A	00	08	35				06	08	00
B	42	52	00	42	43	25	04	40	15
C	207	30	15	164	38	15	359	31	45
A	00	08	30	152	38	15	06	10	20

TABLE I *Telescope readings*

- (i) Most survey stations will require the sighting and recording of far more than the minimum three stations, exemplified here.
- (ii) Always repeat the first observation at the completion of the theodolite telescope traverse; i.e., close the circle.
- (iii) Horizontal differences should always add up to 360°; check that this is so. (See also (vii) below.)
- (iv) Repeat the above survey but with Face Left readings. Thus Table I will only be half the page of results.
- (v) Do not predict the Face Left readings from Face Right results, the latter may be wrong.

- (vi) Check any apparent difference between FR and FL results whilst you are still at the station, however cold, wet or hungry you may be. The important task of noting discrepancies could be the responsibility of your assistant who is booking the results.
- (vii) On a 20-second vernier-scale theodolite, you should not expect to find more than  $\pm 20$  seconds of arc difference between similar readings, nor more than  $\pm 30$  seconds of arc difference between the first and last reading when closing the circle. Corrections should be made in a proportional manner; see subsequent tables.

More examples of how to construct tables and record particular data relevant to specific instruments or techniques will be given in forthcoming sections. Remember that all tables should be preceded by information on dates, times, location (i.e. station no.), weather, visibility and the name of your assistant. With reference to theodolite work, the assistant booking your shouted telescope readings should have gained experience at this task during the pilot project in phase one.

## FIELD TECHNIQUES

This section discusses the various techniques that may be employed to assist the production of a map. It is understood that you are now familiar with all the instruments discussed above.

### *Tacheometry*

Tacheometry (or tachymetry) is the art of measuring distances. It involves several techniques to locate detail, particularly spot heights for contouring, and permit rapid reconnaissance surveys. In general, the degree of error is of the order of 1 per cent. The bearing, height and distance of points can be obtained by theodolite or telescopic alidade and immediately transferred to the plane table. However, other parts of this paper deal with bearing determinations and so we will initially concentrate on the two basic methods of distance calculations:

- (i) Tangential tacheometry, and
- (ii) Stadia arc.

The latter method is a derivative of the first method. Both techniques are especially useful when it is impossible to measure out distances and height differentials over difficult intermediate distances, for example, over rivers, archaeological sites etc.

*Tangential tacheometry.*—From Figure 7 it follows from simple trigonometry that

$$L = \frac{S}{\tan A - \tan B} \quad \dots \text{equation 2}$$

and the vertical height of *c* above the origin, *o*, is given by

$$V = T + L \tan B - bc \quad \dots \text{equation 3}$$

To simplify the calculation of *L*, vertical angles *A* and *B*, recorded by the theodolite, may be chosen from seven-figure tables (or electronic calculators) so that the difference of their tangents is a simple number, i.e. 1/100, but in such cases the vertical circle should be readable to at least five seconds of arc. It will be noted that greater accuracy will be achieved by maximizing the value of *S* taken from the staff and averaging several readings. Finally, if the horizontal line of sight of the theodolite intercepts the staff then angle *B* may be chosen as zero and only angle *A* need

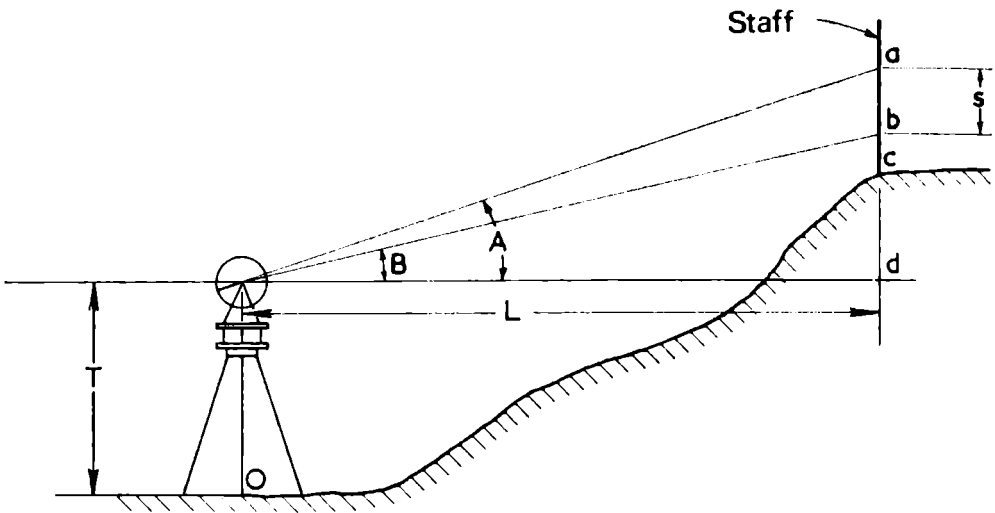

Fig. 7. Tangential tacheometry

be measured. In any case the distance  $S$  is the difference in height recorded from the staff between the last and first angles, i.e.  $ca - cb$ . Thus a simple layout of theodolite readings is required (see Table II) and below a table for calculations can be constructed. Note that the usual data on dates, personnel, weather etc. are required, plus the value of  $T$  for each station. Also, it is not necessary to construct such a wide final table if results are worked out without interruption on a pocket electronic calculator.

Theodolite station	Viewing	Reading		Angle							
		ac	bc	A			B				
				o	'	"	o	'	"		
32 ( $T=1.732\text{ m}$ )	E										
	F										
	25										
	G										
	17										
	3										

$\frac{s}{ac-bc}$	$\tan A$	$\tan B$	$\tan A - \tan B$	$L$	$L \tan B$	$V$

TABLE II Tangential tacheometry tables (a) results (b) calculations

*Stadia-hair methods.*—Most telescopes have stadia-hairs (see Fig. 2) as well as cross-hairs and, when looking through the telescope at a staff, the distance between the upper and lower stadia-hairs,  $\Delta$ , in the telescope will intercept a determinable distance on the distant staff,  $S_\Delta$ .

It can be shown that, with the theodolite telescope in a horizontal plane,

$$L = C_1 S_\Delta + C_2 \quad \dots \text{equation 4}$$

where  $C_1$  (a function of  $\Delta$ ) is a constant of the instrument known as the stadia coefficient, usually 100, and  $C_2$  is frequently negligible. It is advisable to check the values of  $C_1$  and  $C_2$  for your instrument by setting out two known values of  $L$  and determining the corresponding values of  $S_\Delta$  on the staff.  $C_1$  and  $C_2$  may then be calculated as follows:

$$C_1 = \frac{L_1 - L_2}{S_{\Delta_1} - S_{\Delta_2}} \quad \text{and} \quad C_2 = \frac{S_{\Delta_1}L_2 - S_{\Delta_2}L_1}{S_{\Delta_1} - S_{\Delta_2}} \quad \dots \text{equation 5}$$

For the Watts microptic theodolites  $C_1$  is invariably 100 and  $C_2$  is zero.

If the telescope has to be elevated to an angle  $\theta$ , in order to view the staff, then

$$L = C_1 S_\Delta \cos^2 \theta + C_2 \cos \theta \quad \dots \text{equation 6}$$

$$\text{and } V = 0.5 C_1 S_\Delta \sin 2\theta + C_2 \sin \theta + T - W \quad \dots \text{equation 7}$$

where  $W$  is the intercept of the line of collimation (horizontal cross-hair) of the telescope with the staff, i.e. the equivalent of  $0.5(ac + bc)$  of Figure 7.

With reference to Table III, when taking readings from one station (A) to several locations, it is first necessary to know the height of the station relative to some fixed datum (e.g. 27.61 m), the height of the instrument (1.42 m) and hence the reduced level of the instrument (29.03 m). Then for each siting it is only necessary to record the horizontal and vertical angles and the upper, centre and lower readings (U, W, L) on the staff corresponding to the stadia-hairs and the telescope centre line. Tables or calculators will be necessary to compute values of  $\cos^2 \theta$  and  $\sin 2\theta$ . In Table III it is assumed  $C_1 = 100$  and  $C_2 = 0$ .

Remember that computations are simplified if  $\theta$  is zero, and that when concluding a station, it is always beneficial to resite and check the initial reference object, e.g. point B of Table III.

*Other means of distance measurement.*—Two other methods, frequently used for determining distances, have been discussed previously, namely (i) the subtense bar, and (ii) the range finder (see pp. 12, 13).

#### *Setting out the base line*

It is best if this line is a whole number of 100 m intervals and is set out by three persons, plus the surveyor, with a tripod and telescope of either a theodolite or an alidade. One man at the front end of the tape is responsible for marking on the ground the zero marker of the tape scale when the rear end assistant tells him to do so. Prior to this, *double* check and mutually agree where the zero mark of the tape is located since mistakes are costly and not easily remedied. The second man at the rear end of the tape is responsible for keeping the tape taut, knowing how to interpret the ground marker left by the first man, subsequently setting his end of the tape exactly on the marker and signalling the front man that the mark is set. The third man keeps the centre of the tape free of kinks and records in his log book the increment of distance measured *just before* the tape is moved away. The surveyor, meanwhile, makes sure that the tape party keeps in a straight line and signals the front man to move left (or right) simply by walking away to the left (or right) from his telescope. Do not shout information to each other over long distances and do not change your well practised sequence of events and signalling techniques. Optimum distances for base lines are approximately 1000 m. At this distance 50 cm square flags at each of the ends of the base line are easily discernible through a telescope.

TACHYMETRY from Station A

TIME: 1030 hrs

DATE: 4 Oct. '75

WEATHER: Clear

REDUCED LEVEL of STATION A: 27.61 m

INSTRUMENT No: TM 14

OBSERVER: Smith

BOOKER: Jones

HEIGHT OF INSTRUMENT: 1.42 m

RED. LEVEL OF INSTRUMENT: 29.03 m

To	Horizontal		Vertical		Stadia hairs U, W, L	$C_1 S_{\Delta}$	L		H		H - W	Reduced level	Sketch
	o	'	o	'			$100s_{\Delta} \cos^2 \theta$	$100s_{\Delta} \times 0.5 \sin 2\theta$					
B	00	00											
1	03	27	01	20	1.990 1.532 1.074	91.6	91.5	+2.13	+0.60	29.63			
2	48	18	06	20	1.909 1.720 1.531	37.8	37.3	+4.14	+2.42	31.45			
3	71	42	11	40	2.003 1.601 1.199	80.4	77.1	+15.91	+14.31	43.34			
4	75	07	358	20	2.453 1.968 1.483	97.0	96.8	-2.82	-4.79	24.24			
5	116	51	00	00	1.100 0.953 0.806	29.4	29.4	0	-0.95	28.08			
B	00	00	Check										

TABLE III Tables for stadia hair tacheometry

*A tape survey*

A 50 m tape may be the only instrument that is initially required to plot the layout of your area of activity (e.g. a small African village, see Fig. 8). With practice, high accuracy can be attained, i.e. errors less than 1 in 500, but it is necessary to choose your lines of survey with care, so that (i) ends of lines (stations) are mutually visible; (ii) all zones of the area to be mapped are enclosed by a series of well-conditioned triangles; (iii) all essential details are no more than 50 m away from any one tape line; (iv) all stations are clearly marked on the ground and numbered.

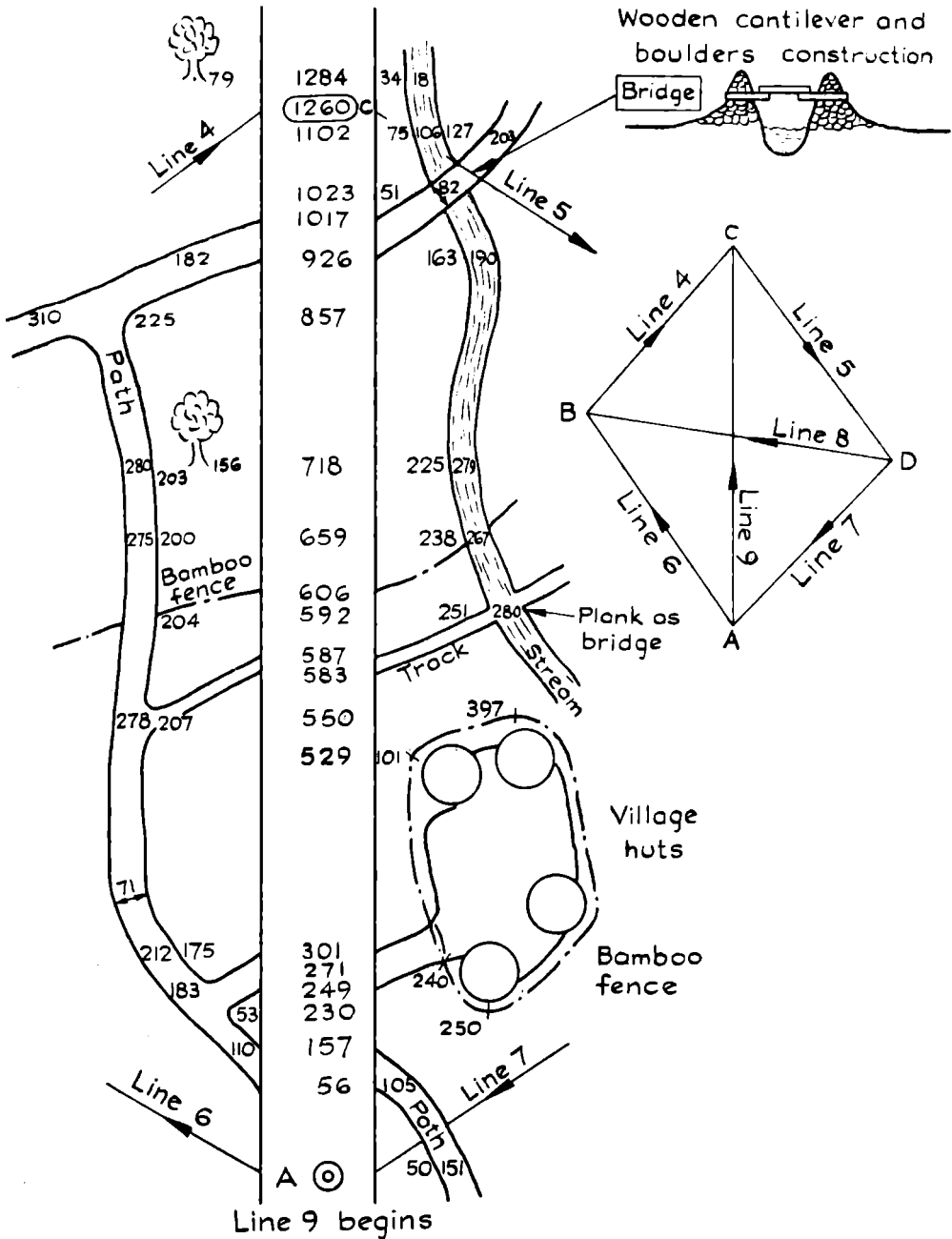

Fig. 8. A tape survey

The technique requires a leader to carry the front end of the tape, a follower for the rear end of the tape and the surveyor who records and sketches all the information. The leader places a marker or peg at the zero of the tape; this is subsequently collected by the follower before he moves on to the second length marker left by the leader. Thus the number of markers collected by the follower indicates the number of tape lengths measured. Practise the art of tightening and marking off tape lengths before starting serious work. Check your technique by measuring out the same line but in the reverse direction.

To locate important details it is best to measure the distance from such details to two points on the main tape line, i.e. form a triangle, but if any detail is very close to the tape line then a simple offset measurement is sufficient. Figure 8 illustrates the method of booking results in your log book. The main tape lines are numbered in the key diagram and the directions taken are arrowed; all stations are lettered (A–D). Start each line at the bottom of a new page. Lengths are usually recorded in 0.1 m intervals, thus the first reading of 56 implies 5.6 m. Offset measurements are always placed nearer to the centre of the page than the detail to which it refers; in the centre column write the distance along the tape at the point where the offset was taken. If necessary extend measurements beyond a station but always circle the measurement that is relevant to the station. At each station indicate the other lines that radiate away from the station, the direction of measurement and the line numbers. There is no disadvantage in adding detail (such as the mode of bridge construction shown in Figure 8), while taping out line 9 if there was insufficient time to record this detail during the traverse of line 5. Remember to note in your log book the time and date at which each line was started and ended, who was in the party and the magnetic bearing of each line.

### *Levelling*

By using a theodolite or a telescope level—simply termed a level—plus a staff, it is possible to determine relative heights of points along a traverse. The staff is graduated in centimetres and the telescope is set perfectly level for each individual sighting.

In order to find the difference in height between two points, say A and B, the surveyor sets the level horizontal at an intermediate station  $I_1$  (see Fig. 9). An assistant holds the staff vertical at A on solid ground and the surveyor reads off height 'a'. The staff is now moved to B and reading 'b' is obtained. Thus the difference in height is (a – b) which will be negative, i.e. the staff is moved downhill. It will be noted that the height of the instrument at station  $I_1$  does not affect the calculation. If the height of a third point C is required, the instrument is moved to station  $I_2$ . When moving the instrument, the staff is kept stationary and vice-versa.

Should heights of intermediate points P, Q, R and S be required then the staff is placed at these points. With practice it should be possible to level to an accuracy of 20 mm per km. In order to assist the surveyor to obtain the true vertical reading the assistant should slowly rock the staff slightly forward and backward and the surveyor will record the smallest reading observed. As a check, the levelling team should repeat the exercise in reverse, that is from the finish to the start of the route, possibly filling in missing intermediate height details.

Table IV presents one common method of recording results known as the rise and fall method. The booking is done by the surveyor who should check the reading immediately after it has been booked. If it is required to determine the positions of stations A, B and C of Figure 9 as well as their relative heights, then the distances between staff positions may be obtained by taping (or other techniques previously



discussed). Furthermore, if the line of the traverse is not straight, it will be necessary to obtain the horizontal bearing, angle  $\phi$ , between AB and BC of Figure 9. It will also be prudent to take frequent bearings to known control points along the traverse.

If a rapid and long traverse has to be achieved in a short time, a system employing two surveyors with theodolites and two assistants with staffs will suffice. You will have to work out the necessary procedure to be adopted in the field where it may not

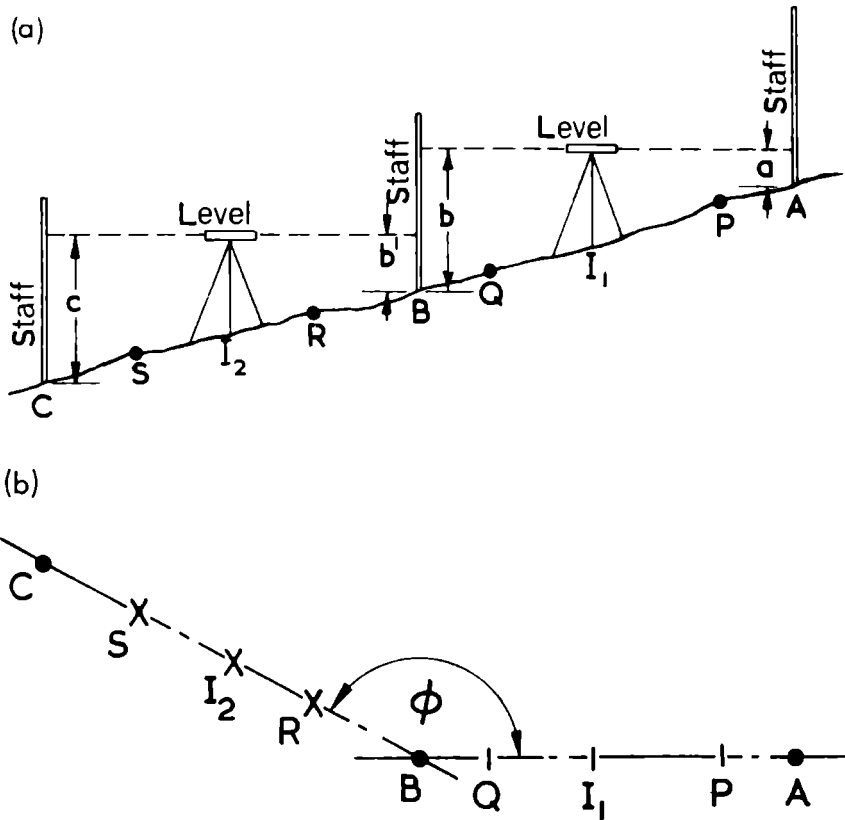

Fig. 9. Levelling (a) side view (b) plan view

be possible to communicate instructions by shouting between all four personnel. Before solving this problem decide what readings must be taken by each surveyor in order ultimately to achieve a satisfactory combined analysis.

#### *A theodolite traverse*

It may be desirable initially to set out the boundary area of your map by a theodolite and tape traverse (see Fig. 10). The theodolite is set up at each station in succession; the back station just vacated (reference object, RO) and the forward station (to be visited next) are observed and recorded. If the ground is not flat, then vertical angles are required in order to compute true horizontal displacements between stations from the taped distance measurements. In order to avoid making continual corrections for the height of the theodolite plus tripod (variable at each station), simply tie a piece of string around a plastic pole coincident with the height of the theodolite before taking the pole to the forward station and sighting on the

## DATUM LEVEL 105.66

Back-sight	Inter-mediate	Fore-sight	Rise	Fall	Reduced level	Tape distance	REMARKS
Ⓒ 1.865					105.660		Datum
	2.440			0.575	105.085	0	Centre of bridge at P
	1.380		1.060		106.145	14	
	2.925			1.545	104.600	28	
	0.440		2.485		107.085	40	Centre of path
Ⓓ 2.200		Ⓑ 1.315		0.875	106.210	58	
	2.875			0.675	105.535	71	
		Ⓐ 0.165	2.710		108.245	88	Edge of woods
4.065		1.480	6.255	3.670	108.245		
1.480			3.670		105.660		CHECKS
2.585			2.585		2.585		

TABLE IV 'Rise and fall' tabular method for levelling

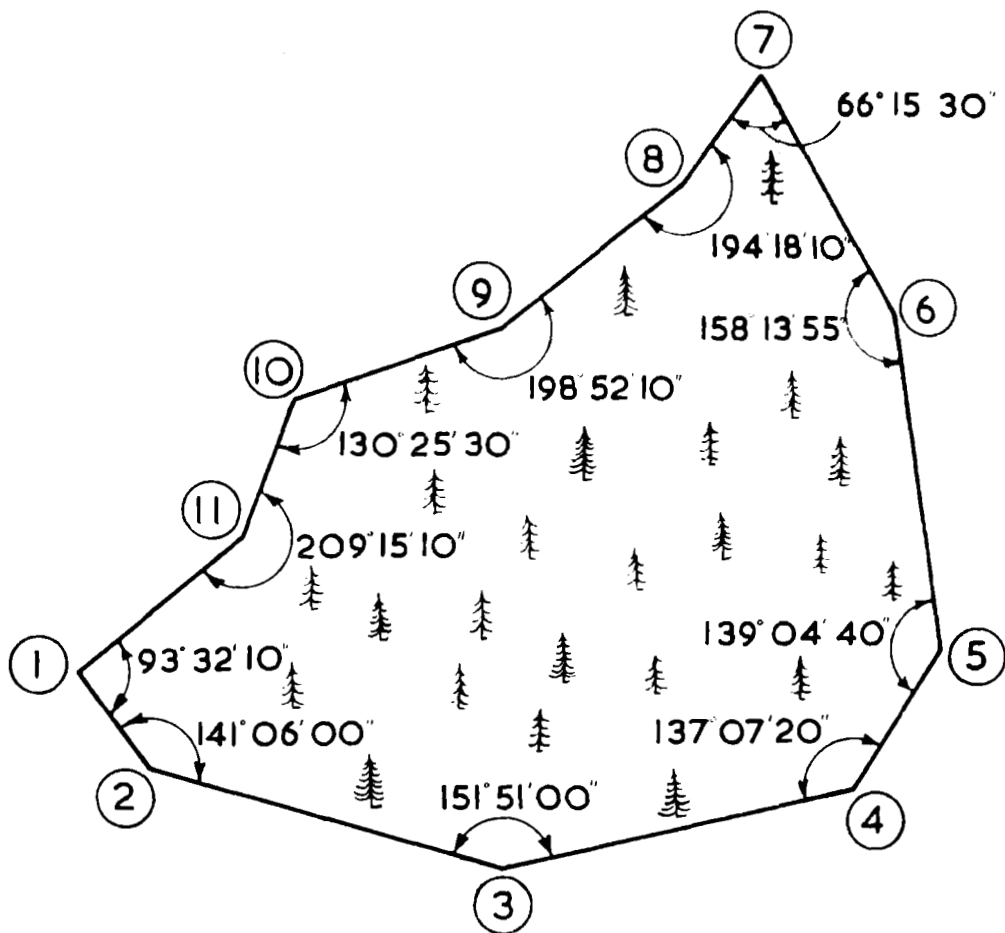

Fig. 10. A theodolite traverse

string. A typical result is shown in Table V. Important points to note are (i) the theodolite should be accurately centred over each station otherwise the polygon will not close; (ii) a magnetic bearing should be taken for at least one of the legs of the polygon; (iii) if the traverse is open ended and part of a larger survey, remember as a check to take frequent bearings on other known stations that may not necessarily be part of the present traverse; (iv) the summation of internal angles of a polygon of  $n$  sides should be  $(180n - 360)^\circ$ .

Finally it will be noted that pacing between stations has been used as a rough check in Table V. The pacing method has an approximate 2 per cent error. Should you employ this method to ensure no gross errors are made, remember periodically to check your *natural* pace over a distance that is measured by tape only after you have paced out 100 strides or some greater but equally simple divisor.

#### Plane tabling

The art of plane table mapping is highly recommended to small expeditions. The technique produces an almost instantaneous map. The advantages of the technique are that the map is drawn during the course of the expedition and is therefore of immediate use to all members; mistakes are soon recognized and corrected; and, finally, the map can be produced by relatively unskilled operators and at a rate

TRAVERSE OBSERVATIONS from ③

INSTRUMENT: WM1 TM 9

DATE: 25 Oct. 74      TIME: 0830 hrs

WEATHER: Clear

OBSERVER: A. Smith

BOOKER: E. Brown

CL, SR/ CR, SL	Stations	H / V			<u>Reduced to RO</u>			<u>Accepted angles</u>			
		o	'	"	o	'	"	o	'	"	
<u>Horizontal</u>											
Face left	Station 2 (RO)	00	03	00							
Swing R	Station 4	151	53	50	151	50	50				
Face right	Station 2	180	15	55							
Swing left	Station 4	332	07	05	151	51	10	151	51	00	
<u>Vertical</u>					<u>Referred to horiz.</u>						
Face left	Station 4	358	34	25	-01	25	35				
Face right	Station 4	181	23	40	-01	23	40	-01	24	38	
<u>Taping</u>											
Tape No. 2		③	-	④	175.569			} 175.573 m			
		④	-	③	175.577						
<u>check by pacing</u>		173 m									

TABLE V Booking of a theodolite traverse

complementary to other data being collected in the field by other members of the expedition pursuing their own particular projects. However, this simple technique of mapping is an art form and requires much practice if great accuracy is to be achieved. In simple terms the map is constructed by forming an expanding series of triangles as the plane table is taken from station to station. The method requires a knowledge of the properties of triangles, hence the term 'mapping by triangulation'. The major items required are an alidade, previously described, and a horizontal plane on which to draw the map (the plane table), plus a pencil and note book.

At this stage we will assume that you now know how to set up a telescopic instrument and to take and record readings. Further, the major control has been agreed, possible stations visited by the surveyor and the base line laid out or its location agreed (see Fig. 1). Several sheets of paper have previously been attached to the spare plane table while only three or four sheets are held on the plane table to be used. Secure the sheets with only one short cross piece of drafting tape at each corner of the table (see Fig. 6) so as not to build up corner height and upset the alidade level. If conditions are likely to be very damp, slide the table, with sheets attached, into a home-made plastic sleeve before inserting the table into its canvas satchel. Tracing paper in particular should be protected; it shrinks on becoming damp and is also affected by heat. Ancillary equipment should be packed in easily located places such as the alidade box.

*Setting-up procedures.*—The tripod is placed with the legs equally spaced and the feet firmly set into the ground. The height is judiciously set, not so low as to be uncomfortable for drawing; not so high as to reduce stability. Before tightening the leg clamps, place the spirit level on the tripod plate and along a line joining the top of two legs. Adjust these legs until this line of the plate is seen to be level. Now rotate the level through  $90^\circ$  and adjust the third leg; this procedure is similar to the levelling of a theodolite previously described. Check that the legs are now rigidly fixed in the ground, nip the clamps, check the level, tighten the clamps. Make certain no straps or obstructions interfere with your movement around the tripod.

Place the plane table on the tripod plate and orientate the table in the most favourable direction, i.e. with its major and minor axes in sympathy with the axes of the area to be mapped which is not necessarily parallel to the conveniently chosen base line. Lock the table rigid by tightening the underneath clamp of the tripod plate.

If the location of a very long base line, possibly on non-rigid ground such as a glacier, has been agreed but not its exact position, it may be best to measure out the exact base line length at the same time as the surveyor starts mapping at one end of the line. He can then help in the setting-up procedure by using the telescope to assist in keeping the tape party in a straight line and noting the position and degree of visibility of the survey marker flag at the far end of the base line. By this technique it is possible to have an excellent but temporary base line as long as 1500 m. Remember to tape the distance in both directions and correct for vertical displacement.

Take out the alidade and place it on the table. Focus the cross-hairs sharply, sight the far end of the base line, move the parallel beam edge of the alidade base to the position chosen for the base line orientation and position on the map, lightly clamp the beam with finger pressure, draw the pencil ray across the sheet. Slightly oscillate the table to make certain that it and the alidade spring back and come to rest with the view through the telescope undisturbed.

Adjustments of the alidade to position the instrument correctly on distant

objects is by slight movements of either of the extreme ends of the alidade base plate. Except when checking the stability of the table at the commencement of the station, there is no further need to touch either the table or the tripod.

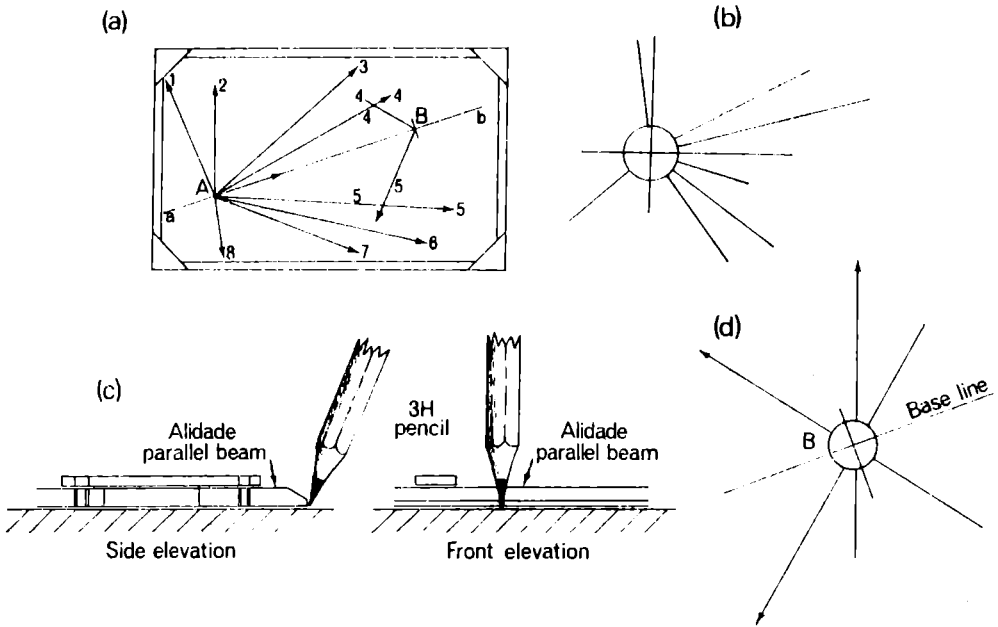

Fig. 11. Principles of plane tabling

Referring to Figure 11, the board will now be positioned at station A and rays will be drawn to all relevant details. Note that:

- (i) Point A is best drawn as in sketch (b), i.e., with only two intersecting lines.
- (ii) Until you have an approximate idea of distance, it is best to project faint 3H pencil lines across the whole board. This must be done for the base line, which is the first ray to be drawn and the last to be checked.
- (iii) All lines should be so faint that only you can see them.
- (iv) All rays should be labelled in soft HB pencil.
- (v) If the immediate area is to be your major control, but you intend to extend the map, then it may be wise to draw two maps whilst at station A, the second one to a smaller scale. This will save time on map reduction at base camp and provide a simple checking system.
- (vi) Remember that possibly the most difficult art in plane tabling is to be able to draw long straight lines along the edge of the alidade parallel beam. To achieve this the pencil should always be held in the same near vertical position (see Fig. 11c) and the lead should always be sharp and chisel pointed.
- (vii) Each and every ray should be checked through the telescope immediately after it has been drawn. All major rays should be noted in the log book along with the elevations.

It should be noted that the major human error in plane table maps is due to the inability to draw straight lines through a point. Referring to Figure 11d, none of the rays shown pass through the station although they appear to do so. The only solution to this problem, and to achieve the necessary standard, is practice. Finally,

before leaving station A, place only the trough compass on the table and when it points to magnetic north carefully draw the ray of the bearing along the edge of the compass on to the drawing sheet.

*The next station.*—When all initial and important rays have been drawn from station A, it is possible to move to the next station—in this case the other end of the base line, station B. At station B, and at all subsequent stations, the table must be accurately oriented in a specific direction, e.g. when at B, with the line ba pointing directly back to A. Having set up the tripod, but with the plane table unclamped, place the alidade on the table with the beam edge along the line ba which should have been drawn the whole length of the board. Without moving the alidade, swivel the board until the marker at A is sighted and exactly centred in the telescope; now lock the table with the underneath clamp and check that no disturbance has occurred to the view. An approximate initial alignment can be made via the bearing of your trough compass.

Since distance AB has previously been accurately measured, it can now be marked off to the required scale on the map line ab. It is necessary to mark off this distance exactly, since even the width of the pencil ray may eventually cause unacceptable errors. (If you do not understand the significance of this last sentence it is because you have not yet had the required practice.) With the alidade now centred and pivoted on point B, it is possible to draw rays from B to those objects numbered 1 to 8 in Figure 11. The intersection of two rays with identical numbers gives the exact position of that numbered point in relation to points AB both in real space and to the scale of the map. Before any point is accepted as being accurately positioned, however, three or more rays should intersect the same location exactly. With reference to Figure 1, let us now assume that points 1 and 3 have been positioned (though not yet checked) from the base line. Move to station 3, set up the alidade on line 1-3, and check that points A and B and all other control points are accurately intersected. If they are, then you have met the necessary conditions required to start a map. You may continue with the line 1-3 now being your new base control, since it is much longer than A-B and was chosen initially so as to give wider and more extensive vistas. If you do not have immediate success, start again—the practice will do you good. Do not attempt at this stage, or any stage, to apply intelligent guesswork. The loss of a few hours work at this stage of the expedition is of little or no consequence. Finally, it is desirable to check the direction of magnetic north on your map with the aid of the trough compass at all subsequent major stations.

*Resectioning.*—At plane table stations, it will not be possible to sight all the locations you desire. However, by resectioning from other future stations, it is possible to fix these difficult positions, as is shown in Figure 12. Assume that point C can be clearly located only from one end, B, of the known base line AB and that D is a station which could not be located from B and C due to poor weather conditions, but was clearly seen from A. Starting at A draw a ray towards B and mark off distance ab to a suitable scale that represents the known distance AB. Draw in a ray to D before moving to station B. From B orient the table so that ba points back to A. When plane tabling, the field station itself is referred to by the capital letter A, but becomes a on the actual plane table. Next, draw a ray to C. Go to C and orient the table so that vector cb points back to B. Point C is established by resectioning, simply by fixing point A in the alidade telescope and then drawing the ray backwards from point a to cut the previous vector. Thus point C is mapped. Point D position is also found by resectioning on C after aligning the table along ray da and checking with the position of B.

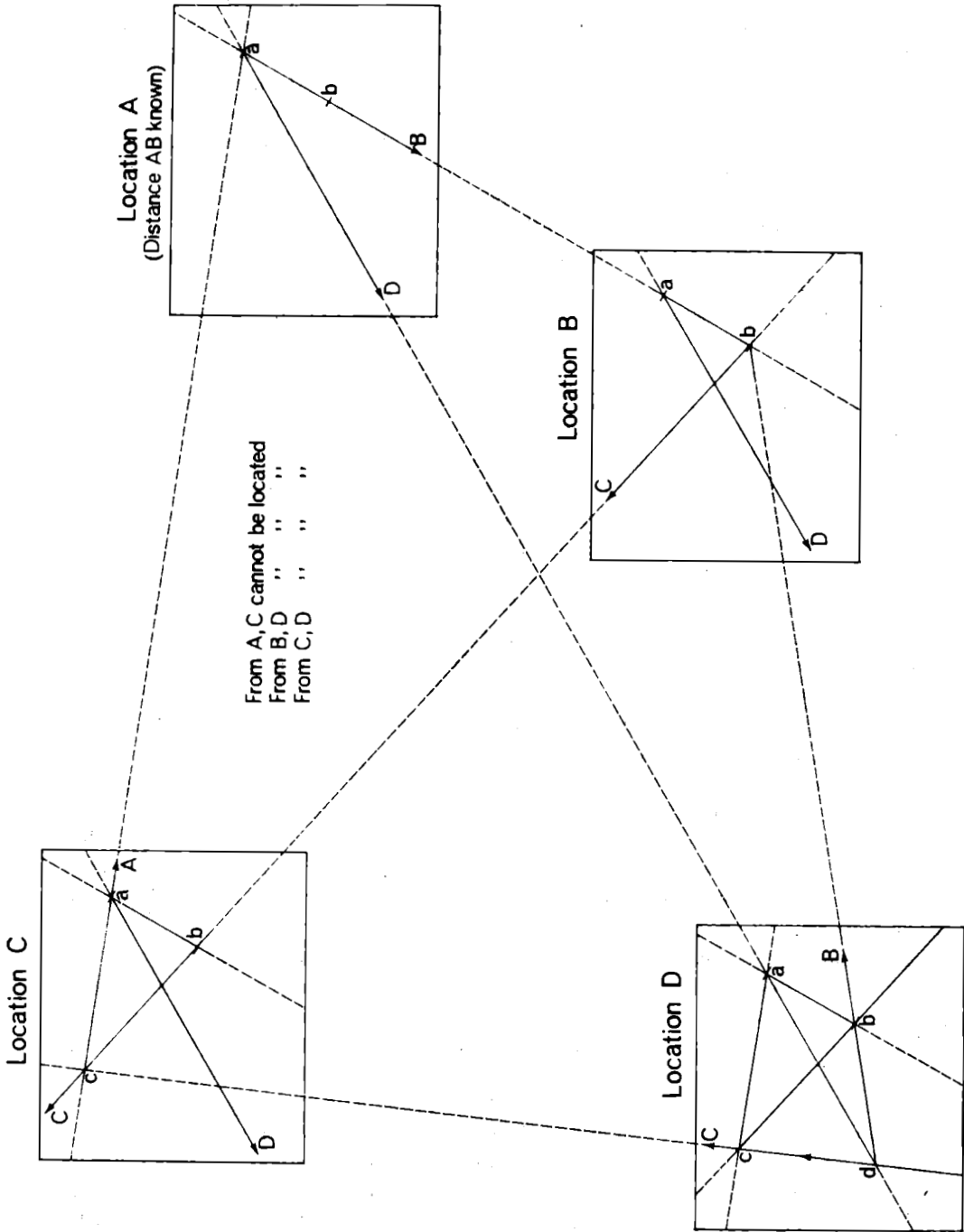

Fig. 12. Resectioning



Thus resectioning is the technique of determining one's position by viewing a previously located station. This technique can be applied to a situation where three or, better still, more points may be known, but the location where you now find it desirable to set up a station is not known. For example, while travelling, you have unexpectedly come across a depression, P, which contains a hidden lake that must be mapped. Take a sheet of tracing paper and draw the rays from the point P radiating out to known points X, Y and Z. Take the sheet of paper and move it about over the top of your map until all rays pass through the previously located points x, y, z. Your present position on the map now coincides with point p which can be pricked through the tracing paper on to the drawing sheet. Other methods are available but they require more time and necessitate more detailed construction (see Sandover, 1961). The major difficulty in this method of tracing from only three points arises when all four positions (X, Y, Z and P) approximate to positions on the arc of a circle. In fact the optimum situation is for the arc joining x, y and z to be convex to, and some distance from, the point p. Also it is better to have as many resectioning rays as possible.

*Height determinations.*—This information may be achieved by any of the methods previously discussed, but it should now be clear that plane tabling permits the horizontal distance between points to be measured directly after sectioning or resectioning such points on the plane table. Therefore all that is required is the elevation angle of the point relative to the station in order to calculate the height difference.

When taking an elevation reading from the alidade, always level the instrument by adjusting the axis until the bubble of the instrument spirit level is centralized. Since rays may be bent in the atmosphere, it is always wise to take the average of the two elevations, A looking up to B and then B looking down to A. The calculated height of all major control points should agree from at least three stations before acceptance.

One type of alidade, the Indian clinometer, is non-telescopic and of simple construction. Objects are sighted through a pinhole on a vertical arm, and on through a slit containing a dividing wire on the opposite vertical arm of the instrument. The forward arm has a graduated scale of angles and tangents alongside the slit to assist rapid analysis of heights. The zero of the scale is directly opposite the viewing pinhole. This instrument is useful for plane table mapping in very rough, mountainous country; to some degree, it combines the advantages and disadvantages of the telescopic alidade with the most common type of simple alidade, which has a thin, long viewing slit to replace the pinhole of the Indian clinometer, although the forward vertical arm still contains a vertical hair on which to sight distant objects. It has previously been shown that the height of a distant object relative to the station is given by

$$V = 0.5C_1S_{\Delta} \sin 2\theta + C_2 \sin \theta + T - W \quad \dots \text{equation 7}$$

The major component to be measured by an instrument is the first term of equation 7 since  $C_2$  is frequently negligible or zero. One means of simplifying calculations is to have an accessory, the Beaman stadia arc, clipped to the vertical circle of the alidade. This arc is usually graduated in equal increments of  $\sin 2\theta$  equal to 0.02. If the constant,  $C_1$ , of the instrument is 100 then

$$0.5C_1 \sin 2\theta = 1 \text{ increment of scale} \quad \dots \text{equation 8}$$

To avoid confusion between angles of elevation and depression, the increment reading, R, of the instrument is often made equal to 50 when the telescope is

perfectly horizontal. Thus when the far staff is sighted and  $S$  determined, the value of  $V$  is simply calculated from

$$V = S_{\Delta}(R - 50) + T - W \quad \dots \text{equation 9}$$

assuming of course  $C_2$  of the instrument is zero. Note also that the factor  $T - W$  may be negligible.

*Rapid insertion of detail by plane tabling.*—Have an assistant set up a distant plane table at a proposed intermediate station while you work at another more important table on which the rays not only extend to the edges of your sheet but beyond and on to the edge of the underneath sheet. This permits you carefully to remove the top sheet, take it to the other table to draw the complementary rays, and then to return to the first table and rapidly relocate and fix the sheet back in its original position in order to add even more detail. Meanwhile your assistant moves the second table to a different locality.

If time is desperately short, then several sheets of paper can be used on which to draw rays from positions which can be located by resectioning after the return of the expedition. Thus there is no need to orient the plane table at such positions with great precision. With only 10 or so rays radiating out from the centre of a drawing sheet at any one position, it is possible to use the same sheet of paper for several intermediate stations, although extra care will be required to avoid confusion when numbering the rays. It is suggested that the sheet will be numbered and recorded in the diary for a particular day's work, and so rays may simply be labelled, e.g. 3/51 or 5/72, the first number indicating the station, and the second, the object to which the ray is directed.

#### *Combination of techniques*

Plane table mapping will benefit from the experience gained in all the different survey techniques previously outlined. Forming well-conditioned triangles, resectioning, tape surveys, tacheometry and height determinations may all be employed whether the expedition is traversing, forming closed polygons at a permanent base, or inserting intermediate detail. However, in order to obtain the maximum benefit from, and efficiency in, this most enjoyable form of mapping, it is recommended that surveyors should not only be well versed in the use and applicability of all the individual instruments and techniques, but that, for a particular set of circumstances, a combination of techniques may provide the optimum method of obtaining results. Thus with reference to either the tape survey illustrated in Figure 8, or the theodolite traverse of Figure 10, it is possible to set up a plane table at any one of the ends of the taped lines and radiate rays to many more features which can then be measured by tacheometry, or by tape, and the distance immediately marked off on the map. The combination of techniques used will depend on the size of the map to be produced, the number of surveyors, the terrain, and the experience gained in phase one of the expedition.

#### *Contouring*

In order to show the general relief of the mapped area, i.e., ridges, valleys, etc., it is desirable to place lines of constant level, at regular height intervals, on the map. These *contours* provide the third dimension to the previously two-dimensional picture. This important contribution to mapping is illustrated by Figure 13. This shows a pingo whose approximate boundaries ABCDE have been laid out by a theodolite and tape traverse, or by plane tabling from a distant base line. The apex ridge of the pingo is identified by PQRS. Thus a theodolite or plane table triangulation establishes the major control. Obviously the choice of the aforementioned points is crucial if one wishes quickly to plot the important detail of the pingo,

since a series of rays from these stations will be the lines along which levels are taken. For example, note the positioning of PR and QS in relation to both the small lake edge and the external and internal ridges of the pingo. Furthermore, uniform coverage has been attained with a minimum of rays.

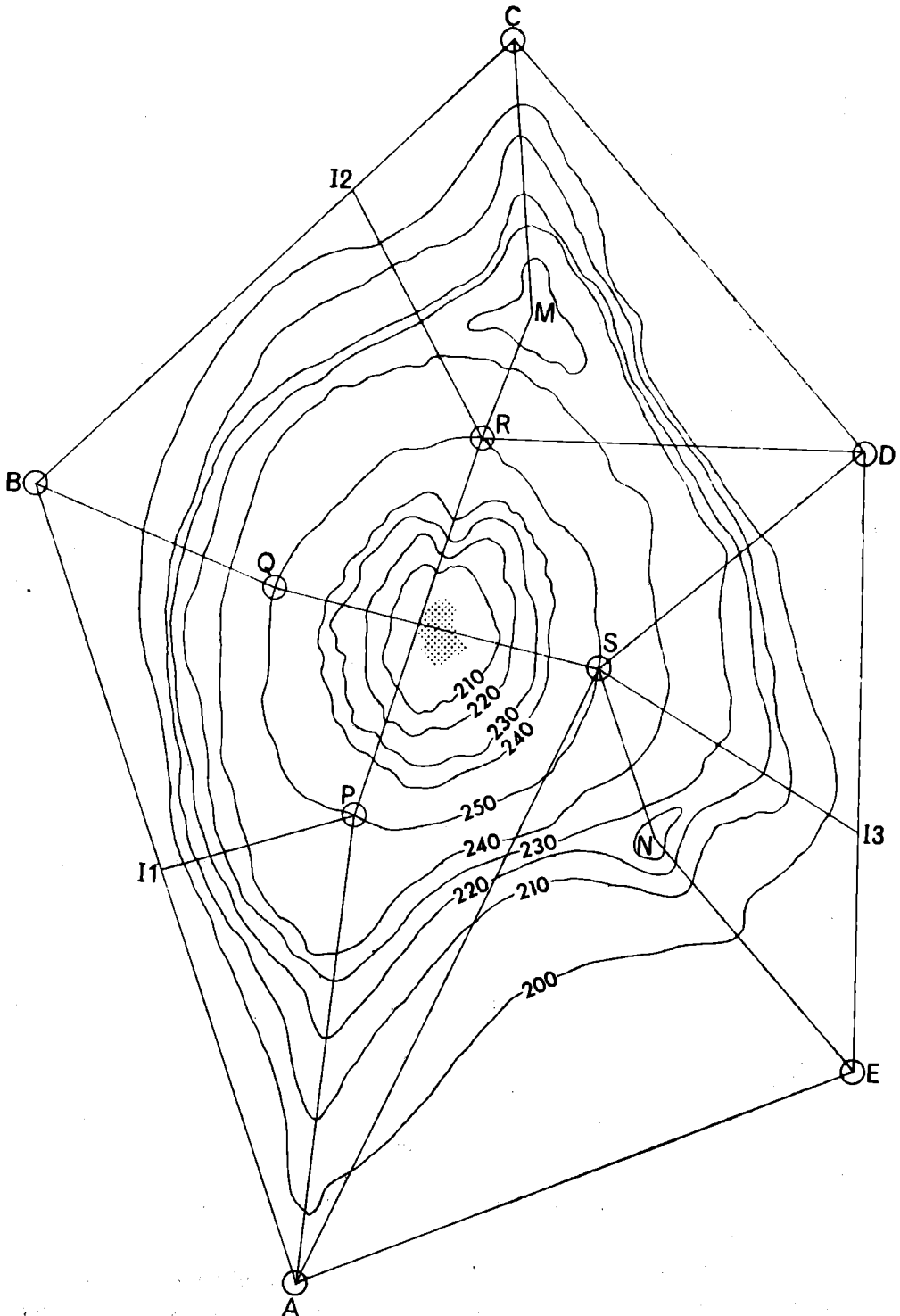

Fig. 13. Contouring a pingo

The example serves to show that many spot heights are needed for contouring. For small features such as a pingo or a depression, one simple technique is to set up the theodolite at various levels some distance away from the zone. Then, with the instrument set horizontal at each height, another member can place pegs or other markers at regularly spaced horizontal intervals on the feature to be contoured. These pegs can then be rapidly intersected by plane table triangulation and height differentials calculated.

Another method, useful for the laying out of pegs at an approximately equal height increment, is to start at the top of the feature with a pole which has a piece of string at eye level. Descend the slope until, at eye level, the string is horizontal to the first position, then mark off the spot with a peg. Continue downhill until a set of levels is established. Determine the position of the pegs by plane tabling and ascertain accurate heights from elevation readings of a theodolite or telescopic alidade. Another method suitable for contouring will be given later, but you are advised to decide on the technique you will use long before leaving the UK and to obtain practice in this and alternative techniques. Several different combinations of techniques can be employed, but the enjoyment of mapping is largely derived from working out your own techniques; these should, however, be based on the fundamental methods outlined in this paper.

#### *The plane table map*

Having established the major control, the map should start to take shape after only a few stations have been visited by the plane tabler. This point is illustrated by Figure 14. The initial base line, ab, has been set out, followed by a new, but longer base, cd, determined by triangulation. These latter two points are set out on flat zones of prominent ridges giving wide views of the area. The original base line has been extended and checked by triangulation to point e, close to the village. Previous trig stations TS<sub>1</sub> and TS<sub>2</sub> are intersected and the distance between TS<sub>1</sub> and TS<sub>2</sub>, already known, is a check on the accuracy of the base line lengths and positions. With the major control now set, the major detail is added, e.g.,

- (i) The boundary posts of the village which will subsequently be the subject of a detailed tape survey.
- (ii) The main zones of the pathways located, as also bridges and any other main features such as the unusual undulations marked 'Burial Mounds'.
- (iii) Streams, rivers and fording places.
- (iv) The initial datum height contour, pegged out and surveyed.
- (v) Magnetic North bearing clearly established.
- (vi) Prominent features located, (especially those on the map boundaries, e.g., the rock spire), in order to achieve greater accuracy and facilitate extension work and resectioning.
- (vii) Some initial contours drawn (e.g., down from the pass used by the expedition to gain entry to the area), principally in the vicinity of mountain streams since two topographical features, i.e., stream lines and contours, are thereby established in one operation.
- (viii) Extension zone overlaps accurately positioned. For example, the base camp and hillock 5 could form the new base line for extending the map downstream.

It will be noted that the far ridge is initially sketched in as observed by the plane tabler. Such a pictorial view will greatly assist in the later, more accurate and detailed mapping of the ridge.

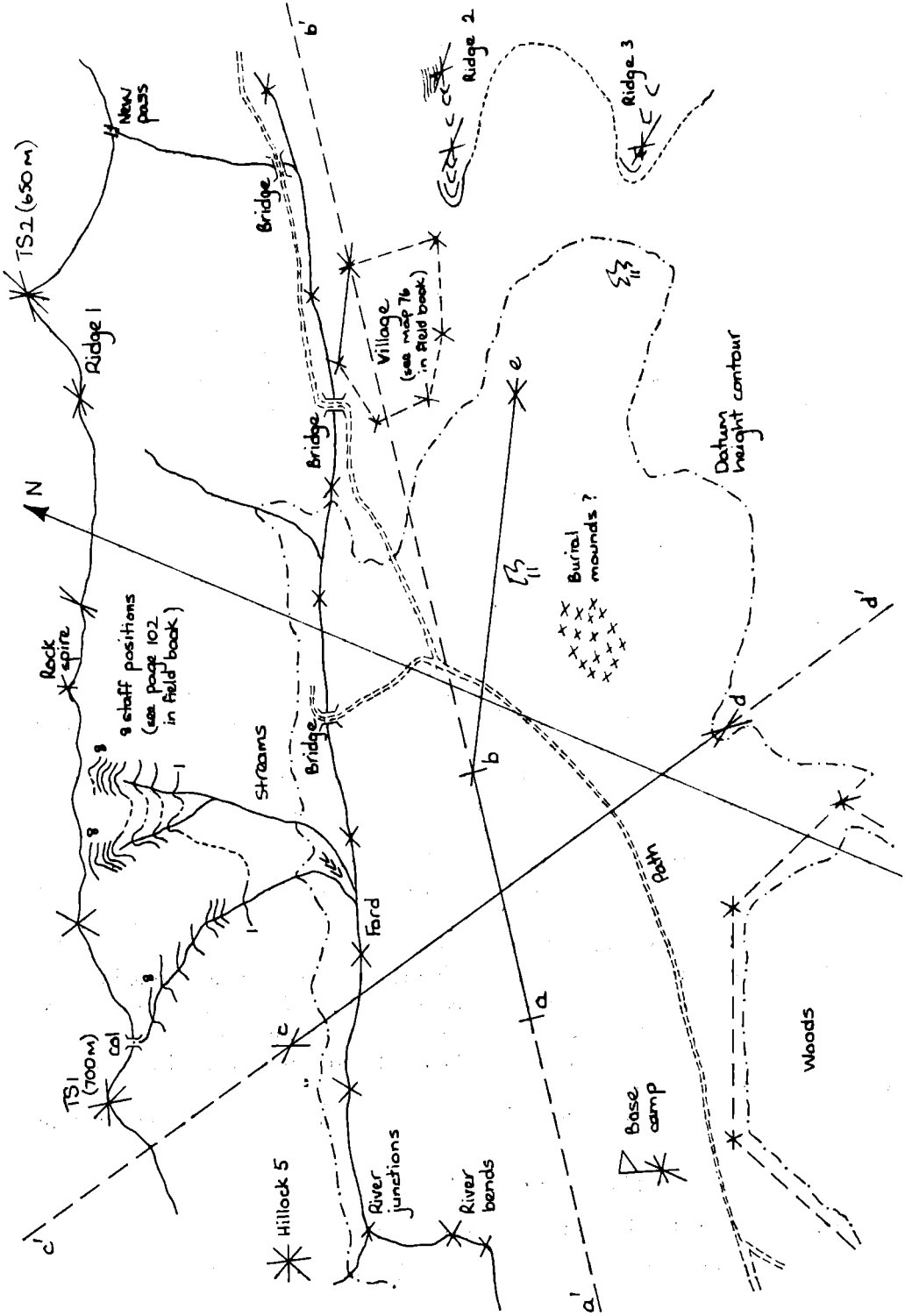

Fig. 14. An embryo plane table map

## COMPUTATIONS

From the layout of tables so far presented, you will note that a neat and logical order is desirable. Certainly this must be the case when calculations are to be made from the tabulated raw data; for an example, see Table II. Frequently more detailed, progressive and extensive computations, with checks, have to be tabulated; this section will deal with this aspect of survey work.

Before starting work at a station, jot down in your notebook the probable headings of data that you will record and calculate. Put these headings in a logical sequence. State clearly all datum (reference) information and, when deleting information, simply put one pencil stroke through the information and do not totally obliterate the initial reading. Place the new information alongside the deletion in clear style.

*Grid calculations.*—Sometimes it is convenient to determine the position of the major control points, at least, of a triangulation with reference to the origin of a square grid network. Let us assume that the origin is arbitrarily chosen as the origin of  $x, y$  axes which may be, but are not necessarily so, the east–west and north–south directions of your map. In the calculations that follow one ignores the curvature of the earth and the convergence of the meridians, and so the computed grid bearings will deviate increasingly from true north bearings as the map extends. However, when the grid data are computed, it is much simpler to construct new maps of differing scales and extend zones to grid boundaries of previously drawn maps: this will permit future expeditions to the area quickly to draw their own grids and networks before leaving home. For the example given below, step-by-step calculations are presented so that the sequence of operations is clearly understood. The surveyor may subsequently wish to write a small computer programme to eliminate much of the arithmetic, and then, at the termination of the expedition, the raw data need only be fed to the computer for automatic analysis. The system now described is based on the experience of many surveyors—it permits immediate checks to be made at every step and mistakes to be quickly remedied. With reference to Figure 15, the bearing of AB is  $149^{\circ} 31' 15''$ . The east and north coordinates of A are assumed to be  $E_a = 1000$  m and  $N_a = 1000$  m and this will ensure that all coordinates of B, C, D, E and F will be positive. It is required to find first the coordinates of B, then C, then D, etc., and so the angles previously obtained by theodolite (recorded in a form similar to Table I) are placed in a new table in order to calculate the required grid bearings (see Table VI). Now, since bearings are measured clockwise and all horizontal circles are graduated clockwise, the relationship between the bearings of new lines (say  $xz$ ) and observed angles to  $y$  (the reference object RO) from  $x$  is simply:

Grid bearing of  $xz =$  grid bearing of known line  $xy +$  angle  $zxy$ . Note the sequence of  $x, y$  and  $z$  and that

$$\text{grid bearing } xz = \text{grid bearing } zx \pm 180^{\circ}$$

(see Fig. 15). Thus in the first example of Table VI:

$$\begin{aligned} \text{grid bearing AD} &= \text{grid bearing AB (known)} + \angle \text{DAB} \\ &= 149^{\circ} 31' 15'' - 105^{\circ} 14' 45'' \end{aligned}$$

since D is anticlockwise from grid bearing AB, so

$$\text{grid bearing AD} = 44^{\circ} 16' 30''$$

(a)

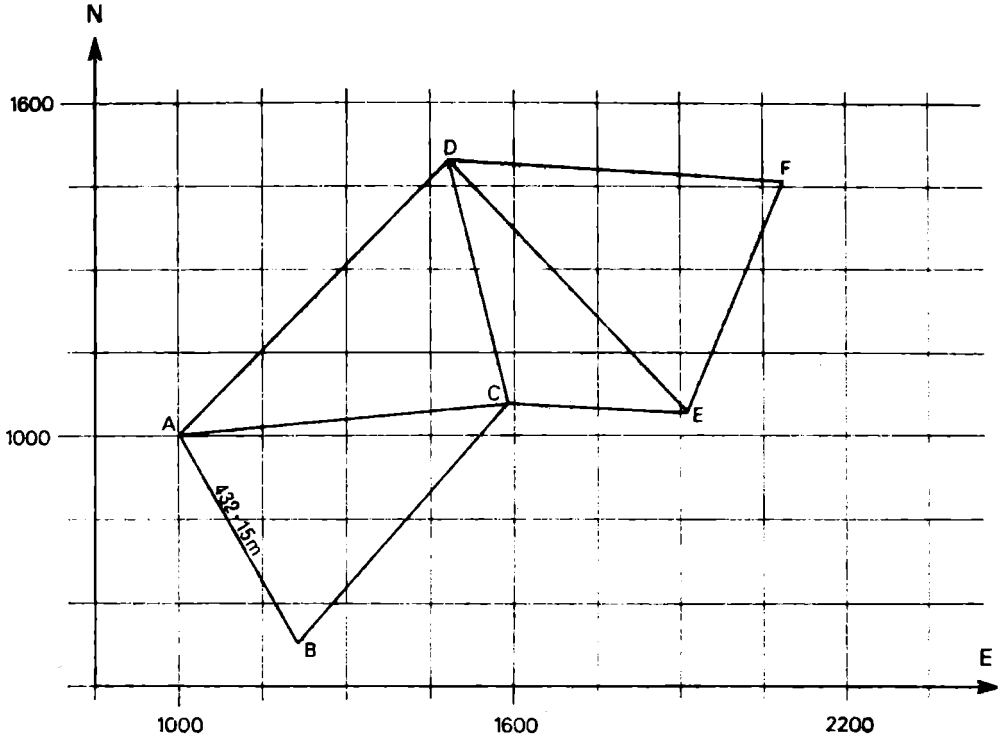

(b)

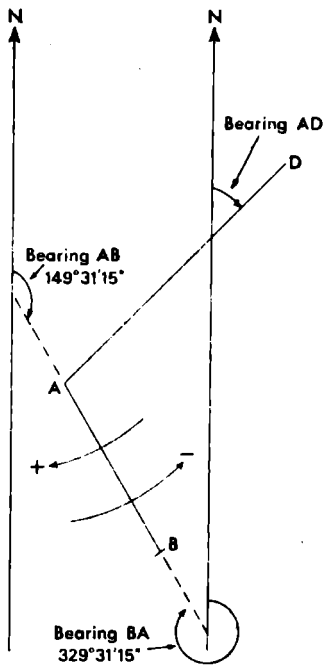

Fig. 15. Grid bearings (a) typical grid network (b) notation for bearings

Station	Angles clockwise from (RO)	Grid bearing of (RO)	Grid bearings
A	(D) 00° 00' 00" C 39 41 15 B 105 14 45	bg AB 149° 31' 15" (datum) ∠ DAB -105 14 45 bg AD 44 16 30	AD 44° 16' 30" AC 83 57 45 AB 149 31 15
B	(A) 00 00 00 C 71 12 30	bg AB 149 31 15 ±180 00 00 bg BA 329 31 15	(BA 329 31 15) BC 40 43 45
C	(B) 00 00 00 A 43 15 00 D 124 15 30 F 196 17 30	bg AC 83 57 45 bg BC 40° 43' 45" ±180 00 00 ±180 00 00 bg CA 263 57 45 bg CB 220 43 45 ∠ ACB -43 15 00 bg CB 220 42 45 Mean bg.CB 220° 43' 15"	(CB 220 43 15) (CA 263 58 15) CD 344 58 45 CF 57 00 45
D	(C) 00 00 00 A 59 17 30 F 287 15 15	bg AD 44 16 30 bg CD 344 58 45 ±180 00 00 ±180 00 00 bg DA 224 16 30 bg DC 164 58 45 ∠ CDA -59 17 30 bg DC 164 59 00 Mean bg DC 164° 58' 52"	(DC 164 58 52) (DA 224 16 22) DF 92 14 07

TABLE VI Calculation of grid bearings



Similarly

$$\begin{aligned} \text{grid bearing AC} &= 44^\circ 16' 30'' \text{ (grid bearing AD)} + \angle 39^\circ 41' 15'' \text{ (\angle CAD)} \\ \text{grid bearing AB} &= 44^\circ 16' 30'' + 105^\circ 14' 45'' \text{ (\angle BAD)} \end{aligned}$$

You will note that:

- (i) from any one station all angles are recorded in a clockwise direction, and this simplifies the final column since all bearings will be increasing in a positive manner;
- (ii) when a grid bearing is calculated twice (e.g. CD of row four in Table VI) the mean value is accepted.

Now that the grid bearings of all rays are known, each triangle is solved by the sine rule

$$\frac{BC}{\sin A} = \frac{AC}{\sin B} = \frac{AB}{\sin C} \quad \dots \text{equation 10}$$

Taking triangle ABC as an example, the angles A, B and C are listed *as observed*, they are then corrected to add up to exactly 180° (see Table VII). Since length AB

	Observed			Corrected			Log BC	2.759 08
A	65°	33'	30"	65°	33'	10"	Log sin A	9.959 21
C	43	15	00	43	14	40	Log cosec C	10.164 24
	AB = 432.15 m						Log AB	2.635 63
B	71	12	30	71	12	10	Log sin B	9.976 20
	180	01	00	180	00	00	Log AC	2.776 07

TABLE VII Calculation of triangle lengths

and its complementary angle C are known, they are purposely placed in the middle of the rows. The unknown lengths are AC and BC which can be determined from the fact that

$$\begin{aligned} \text{Log BC} &= \text{Log AB} + \text{Log cosec C} + \text{Log sin A} \\ \text{Log AC} &= \text{Log AB} + \text{Log cosec C} + \text{Log sin B} \end{aligned} \quad \dots \text{equation 11}$$

In survey computations, 10 is usually added to the logarithms of sines and cosecs so as to avoid negative quantities. To obtain both Log BC and Log AC it will be seen that Log AB + Log cosec C is a common factor in equation 11; hence Log BC is obtained by adding the first three logs, and Log AC is obtained by adding the last three logs, tabulated in the final column of Table VII. Obviously the correction for the additional tens to the logs of the trig functions is attained by not recording the ten digits in the summation. Finally, most surveyors do not constantly repeat the word 'Log' but simply use the letter 'L' as an abbreviation in tables of this form.

The lengths and bearings of all lines are now established (see Tables VI and VII) and it only remains to calculate the grid locations. The coordinates of all points of one triangle are solved and checked before moving to the next triangle. Thus for triangle ABC, for which E<sub>a</sub> and N<sub>a</sub> are each 1000 m (datum), the coordinates of B and C will now be calculated via point A (see Table VIII). As a check, the co-ordinates of C will also be calculated from the coordinates of B. The calculations

are based on the fact that

$$E_B = E_A + \delta E_{AB} \quad \dots \text{equation 12}$$

where  $\delta E_{AB} = AB \sin(\text{grid bearing AB})$

$$\text{and } N_B = N_A + \delta N_{AB} \quad \dots \text{equation 13}$$

where  $\delta N_{AB} = AB \cos(\text{grid bearing AB})$ .

Co-ordinates of B from A					
Log $\delta E_{AB}$	2.340 83		$\delta E_{AB} +219.20$		
Log sin bg AB	9.705 20		$E_A 1000.00$		
Log AB	2.635 63		$E_B 1219.20$	$N_B 627.57$	
Log cos bg AB	9.935 41			$N_A 1000.00$	
Log $\delta N_{AB}$	2.571 04			$\delta N_{AB} -372.43$	
Co-ordinates of C from A					
Log $\delta E_{AC}$	2.773 65		$\delta E_{AC} +593.81$		
Log sin bg AC	9.997 58		$E_A 1000.00$		
Log AC	2.776 07		$E_C 1593.81$	$N_C 1062.81$	
Log cos bg AC	9.021 93			$N_A 1000.00$	
Log $\delta N_{AC}$	1.798 00			$\delta N +62.81$	
Co-ordinates of C from B					
Log $\delta E_{BC}$	2.573 65		$\delta E_{BC} +374.67$		
Log sin bg BC	9.814 57		$E_B 1219.20$		
Log BC	2.759 08		$E_C 1593.87$	$N_C 1062.72$	
Log cos bg BC	9.879 56			$N_B 627.57$	
Log $\delta N_{BC}$	2.638 64			$\delta N +435.15$	
Accepted co-ordinates of C			$E_C 1593.84$	$N_C 1062.77$	

TABLE VIII Calculation of grid co-ordinates

A similar method of addition as presented in Table VII is indicated in Table VIII.

*Computation of a theodolite traverse.*—A similar but more detailed set of calculations is given in Table IX for the complete computation, including heights and checks, of a closed polygon. Distribution of errors in the observations (first column) are indicated and the final row calculation shows that the overall error is less than 1 in 50 000. Such a small error, however, is unusual. The results of Table IX were taken from a relatively horizontal polygon. If each leg of the polygon was at an obvious inclination (greater than 3°) then the horizontal distance (HD) would have to be computed separately and entered in the first column instead of taped (T) distances; also Log HD values would be used instead of Log T values in columns 2 and 4. Finally, the value of Log  $\delta H$  in the second column would have to be modified to the sum of Log HD + Log tan V.

For a closed polygon the summation of all  $\delta E$  values and  $\delta N$  values should separately be zero. It will be noted that the datum coordinates  $E_A$  and  $N_A$  were chosen so as to give positive values of coordinates of all other stations.

The tables indicate that a neat, logical and systematic approach to calculations is essential for the surveyor and the assistant who checks the surveyor's work.

OBSERVATIONS	Log $\delta H$ & log D	GRID BEARINGS	Log $\delta E$ & Log $\delta N$	E	N	H
A to B Angle A 76° 43' 50" V +00 04 40 Tape 92.903 m	log $\delta H$ 9.100 76 log sin V 1.132 73 log T 1.968 03 log cos V - log D 1.968 03	Bg AB 201° 31' 00" (datum)	log $\delta E$ 1.532 43 log sin bg 9.564 40 log T 1.968 03 log cos bg 9.968 63 log $\delta N$ 1.936 66	E <sub>A</sub> 500.000 (datum) $\delta E$ -34.076 + 0.001	N <sub>A</sub> (datum) 500.000 $\delta N$ -86.430 + 0.001	H <sub>A</sub> (datum) 20.000 $\delta H$ +0.126
B to C Angle B 80 42 20 V -00 02 50 Tape 57.257	log $\delta H$ 8.673 85 log sin V 6.916 02 log T 1.757 83 log cos V - log D 1.757 83	Bg BA 21 31 00 /ABC +80 42 20 Bg BC 102 13 20	log $\delta E$ 1.747 87 log sin bg 9.990 04 log T 1.757 83 log cos bg 9.325 73 log $\delta N$ 1.083 56	E <sub>B</sub> 465.925 $\delta E$ +55.959 + 0.001	N <sub>B</sub> 413.571 $\delta N$ -12.122	H <sub>B</sub> 20.26 $\delta H$ -0.047
C to D Angle C 149 47 18 V +00 28 40 Tape 32.787	log $\delta H$ 9.436 81 log sin V 7.921 10 log T 1.515 71 log cos V 9.999 98 log D 1.515 69	Bg CB 282 13 20 /BCD +149 47 18 Bg CD 72 00 30	log $\delta E$ 1.451 03 log sin bg 9.978 23 log T 1.515 69 log cos bg 9.489 79 log $\delta N$ 1.005 48	E <sub>C</sub> 521.885 $\delta E$ +3.184 + 0.001	N <sub>C</sub> 401.449 $\delta N$ 10.127	H <sub>C</sub> 20.079 $\delta H$ +0.279 - 0.001
D to E Angle D 134 47 18 V +00 16 00 Tape 62.670	log $\delta H$ 9.464 90 log sin V 7.667 84 log T 1.797 06 log cos V - log D 1.797 06	Bg DC 252 00 30 /CDE +134 47 18 Bg DE 26 47 40	log $\delta E$ 1.451 03 log sin bg 9.655 97 log T 1.797 06 log cos bg 9.950 67 log $\delta N$ 1.747 75	E <sub>D</sub> 553.070 $\delta E$ +28.250	N <sub>D</sub> 411.576 $\delta N$ +55.935	H <sub>D</sub> 20.351 $\delta H$ -0.292 - 0.001
E to F Angle E 59 15 25 V -01 24 20 Tape 31.513	log $\delta H$ 9.888 18 log sin V 8.389 69 log T 1.498 49 log cos V 9.999 87 log D 1.498 36	Bg ED 206 47 40 /DEF +59 15 20 Bg EF 266 03 00	log $\delta E$ 1.497 33 log sin bg 9.998 97 log T 1.498 36 log cos bg 8.838 13 log $\delta N$ 0.336 49	E <sub>E</sub> 581.320 $\delta E$ -51.429 + 0.001	N <sub>E</sub> 467.511 $\delta N$ -2.170	H <sub>E</sub> 20.642 $\delta H$ -0.773 - 0.002
F to A Angle F 218 44 18 V +00 07 30 Tape 60.750	log $\delta H$ 9.122 34 log sin V 7.338 79 log T 1.783 55 log cos V 9.999 87 log D 1.783 55	Bg FE 86 03 00 /EFA +218 44 18 Bg FA 304 47 10	log $\delta E$ 1.698 05 log sin bg 9.914 50 log T 1.783 55 log cos bg 9.756 27 log $\delta N$ 1.539 82	E <sub>F</sub> 549.892 $\delta E$ -40.893 + 0.001	N <sub>F</sub> 465.34 $\delta N$ +34.589	H <sub>F</sub> 19.867 $\delta H$ +0.133
(Check 1) 720 00 46		Bg AF 124 47 10 /FAB +76 43 50 Bg AB 201 31 00 (Check 2)	Signature: A Smith Checker: B Jones Instruments: TM37, Topo 41 Date: Oct '15	E <sub>A</sub> 500.000 +115.393 -115.398 Σ( $\delta E$ ) - 0.005	N <sub>A</sub> 500.000 +100.72 -100.722 Σ( $\delta N$ ) - 0.004	H <sub>A</sub> 20.000 + 0.824 - 0.820 Σ( $\delta H$ ) + 0.004
Misclose = $\sqrt{[\Sigma(\delta E)]^2 + [\Sigma(\delta N)]^2} = \sqrt{[0.005]^2 + [0.004]^2} = 0.006338$			Perimeter = $\frac{1}{338} \sqrt{[\Sigma(\delta E)]^2 + [\Sigma(\delta N)]^2} = \frac{1}{338} \sqrt{0.005^2 + 0.004^2}$ (Check 4)			

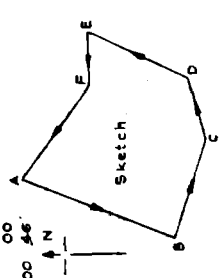

TABLE IX Complete computations of a polygon traverse by theodolite

## SPECIAL HINTS

This final section briefly presents a few notes and hints on a diverse number of unusual topics that may assist surveyors involved in small expeditions.

*Development of techniques*

From simple beginnings, all the above mentioned techniques may be combined and developed by explorers, using a variety of instruments, to suit their particular type of terrain and environment. For example, one expedition working in a glacial valley system containing few survey station sites may require to know transverse and longitudinal contours of the ice cover, as well as ice flow rates. A system could be developed in the field whereby it is possible to establish substantial detail once the major control (e.g., stations 1, 2, 3, 4, 5, 6 and 7 of Fig. 16) is established on surrounding ridges, rock buttresses and pinnacles.

The following systems were devised by a small survey team on a glacier in Greenland. First, the major control was established using a plane table at a temporary base line *ab* on the ice (i.e., non-rigid) and then a derived base line 2 to 4 that was checked from a second non-rigid base line, *cd*, both glacier base lines being set out by theodolite and tape measurement.

*Ice flow rates.*—With the aid of the theodolite on the glacier, approximately equispaced stake poles were set out in straight lines at *RS*, *TU* and *VW*. Theodolite observations from rock stations 1 and 7, 6 and 5, and 2 and 3 respectively, then permitted the determination of the surface flow rates of the glacier at each of the respective stake lines, simply by noting the position of each stake at the beginning and the termination of the expedition.

*Glacier surface contours.*—The surface area of ice to be mapped was that bounded by the stake lines and valley walls. The whole area was traversed by assistants who made sure that they (a) always headed straight towards a fixed feature on the opposite mountain side (although deviations do not affect the results), and (b) stopped for a period of approximately two minutes at frequent intervals en route, say every 50 metres, or at points of interest, such as moulins, melt streams, depressions, surface lakes, ice bulges etc. They recorded in their log books the exact time they stopped at a point, recorded the height of their pole above the ice, and wrote a description of the locality. Meanwhile, two well-practised surveyors, say one at station 2, one at station 4, synchronously recorded by theodolite the horizontal and vertical angular displacements to the top of the flag pole held vertical by the walkers at their points of rest. It follows that for each and every point of rest (e.g., point 8 of Fig. 16), the location can be accurately determined in terms of relative height and position with respect to the surveyors.

A simple computer program was written immediately on returning home that permitted rapid evaluation of ice flow rates and the drawing of a detailed ice surface contour map of the system. At this stage the reader should be aware how positions and movements of stakes can be calculated from the joint knowledge of  $\alpha$ ,  $\beta$  readings and the length of lines such as 2-4; and also the degree of confidence and ability, based on much practice, required by the two surveyors in order to achieve rapid coverage of the area.

*The survey team*

In a small expedition, only one man may be assigned to the day-to-day survey work. Nevertheless, consider the position of the expedition if the surveyor has to

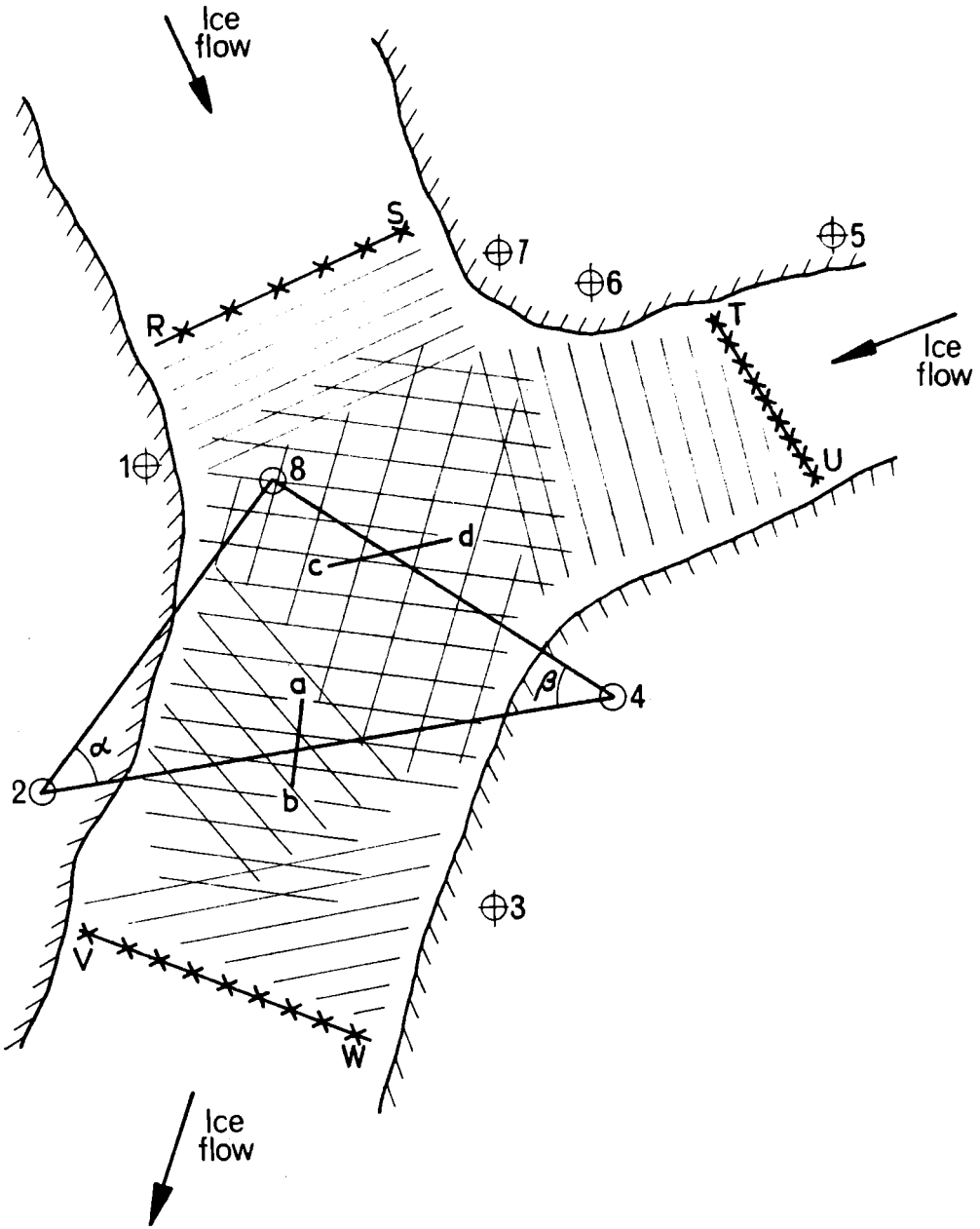

Fig. 16. Glacier topography

withdraw during the course of the expedition through sickness, accident or other circumstances. It is therefore prudent to have another member of the expedition well versed in survey techniques, hence train one other member to use the instruments and record data. This could be done in the early days of the expedition although your colleague should previously have read and completely understood this pamphlet, which should be taken on the expedition.

Furthermore, if time permits, it will be beneficial to the survey project should two plane tablers work together simultaneously. For example, in order rapidly to plot the exact course of a river, moraine, meandering path, boundary wall or some

other such detail, the plane tables can be set up at various stations previously fixed by theodolite. The surveyors then draw rays, on tracing paper, to the staff positions which are intermittently staked out by an assistant, who is walking along the bank of the river, moraine etc. The rays, excluding the original ones radiating out from the centre of the table to at least three fixed points and the other plane table position, are numbered 1105, 1113 etc., which indicates the time in hours and minutes when the ray was taken. The exact position of the staff at any given time can then be ascertained by resectioning techniques involving the tracing sheets of both surveyors. Read also the section concerned with Figure 16.

#### *Aggressive environments*

A plane table can be set up at a station, even in zero visibility, by aligning the table with the aid of the previously drawn magnetic meridian. It is possible that visibility may improve as the day progresses and even the drawing of only one or two rays from a station may eventually prove to be an exceedingly worthwhile day's work.

Protect your instruments and note books at all times. Wipe clean, dry and replace them in their protective covers at the end of each day's work. In windy conditions, anchor all items so that they do not blow away or collapse and damage themselves. Store all items inside a tent or under a tarpaulin. Animals have been known to devour straps and leather boxes. Gloves and other items of apparel should be carefully considered before leaving home. For example, a surveyor working on a theodolite or plane table may require to have individual finger mitts to facilitate manipulation of instruments in very cold environments. In aggressive environments, surveyors should remove snow goggles/sun glasses, gloves etc. only when absolutely necessary.

#### *Assistance by the Royal Geographical Society*

A general comment that should help explorers engaged in any unusual type of survey is that someone, somewhere may have had experience that will be of assistance to you; this experience will probably be recorded in a report, journal or book, a copy of which may be kept at the RGS. A visit to the RGS, with an introductory letter to its staff from a Fellow of that Society, will permit you to study reports, journals, maps etc. of previous expeditions which included survey work in their scientific projects. Fellows of the Society can be found in most university departments of geography and, by showing them this page of this paper, you should elicit some helpful assistance.

For unusual terrain it is often necessary to develop specialized, and sometimes more accurate techniques. These techniques however are firmly based on the fundamentals outlined in this paper. Fortunately, a number of papers are devoted specifically to various types of terrain and these are found in the list of references. *Cave surveying* (Judson, 1974) details techniques useful for underground exploration and mapping by speleologists. *Land navigation* (Hall, 1972) is exceedingly useful for small expeditions travelling overland, particularly in desert areas and where navigation may be a serious problem. *Hints for travelling divers* (Woods, 1973) should be read by those wanting to map, for example, underwater wrecks and archeological sites. *Collection of place names* (Geelan, 1973) should be consulted by expeditions who want guide lines as to what names may be given to features they have located, virgin mountains they have climbed, and so on. It is customary practice nowadays to choose names in the local language, and which have a local significance. *The report of the Cambridge University expeditions to East*

*Greenland* (Miller, 1970) gives details of a somewhat unusual survey technique to record the depth of ice at longitudinal and transverse sections of a glacier, using modified radar devices carried on a sledge. The method of positioning and surveying the route taken by the sledge is also presented in some detail in this reference (2 vols.) which is to be found in the RGS library.

*Accurate taping.*—On stable and flat ground the error in taping can be reduced to about 1 in 50 000 by special techniques (see Cheetham, 1965) although speed is reduced. Basically, the essential points are:

- (i) No attempt is made to match exactly the end and beginning of successive tape lengths. Instead a series of metal plates is used, each plate being securely pegged to the ground. The plates have scribed lines to which exact measurements are made.
- (ii) A definite tension is applied to a steel tape with a spring balance, the tape having been calibrated at that tension and at a specified temperature.
- (iii) A very long tape is employed (100 m).
- (iv) A correction is made for the temperature of the tape under expedition conditions.

Advanced techniques for the optical measurement of distances are given by J. R. Smith (1970). The methods and instruments described in the publication are concerned with more accurate, and/or more rapid, determination of distances. However, as is the case with most modern equipment, the cost to an expedition for its loan and insurance may be prohibitive. Furthermore, the increase in accuracy achieved is probably not balanced by the extra cost.

## CONCLUSION

This paper should make the novice surveyor or any member of an expedition aware that preparations cannot begin soon enough; that pre-expedition practice is essential; that during the course of the expedition patience, planning, drawing ability plus perception are desirable attributes; and that some period of time must be set aside after the end of the expedition in order to complete all the map work.

Of all the various aspects discussed in this paper for each of the three phases of an expedition, the most important is the gaining of ability, and hence confidence, *prior* to the expedition.

*Acknowledgements*

The author would acknowledge any publications on survey and survey techniques but notably *Hints for travellers* by E. A. Reeves, and *Survey notes* by the University of Cambridge Engineering Department staff, both references having given assistance in the preparation of some sections of this paper. This help, plus the constant encouragement and assistance given by A. Stephenson of the RGS, is gratefully acknowledged.

*References*

- Berrangé, J. P. 1975 Advice for small expeditions in forested regions. *Geogr. J.* **141**, 3: 421-9.  
 Cheetham, G. 1965 *Textbook of topographical surveying* (4th ed.) HMSO.  
 Geelan, P. J. M. 1973 Collection of place names by small expeditions. *Geogr. J.* **139**, 1: 104-6.  
 Hall, D. N. 1972 Land navigation for travellers and small expeditions. *Geogr. J.* **138**, 3: 339-46.\*  
 Hamilton, R. A., Biddle, C. A., Sparks, B.W. 1957 Surveying aneroids: their uses and limitations. *Geogr. J.* **123**, 4: 481-98.  
 Judson, D. 1974 Cave surveying for expeditions. *Geogr. J.* **140**, 2: 292-300.\*  
 Miller, K. J. 1971 *Cambridge University expedition to East Greenland 1970 (2 vols)*. CUED Special Project Reports 1 and 2, Cambridge University Engineering Department.  
 Rushworth, W. D. 1975 Electronic calculators for expedition surveyors. *Geogr. J.* **141**, 1: 72-75.\*  
 Sandover, J. A. 1961 *Plane surveying*. Arnold.  
 Smith, J. R. 1970 *Optical distance measurement*. Crosby Lockwood.  
 Woods, J. D. 1973 Hints for travelling divers. *Geogr. J.* **139**, 1: 84-95.\*  
 Wright, J. W. 1973 Air photographs for small expeditions. *Geogr. J.* **139**, 2: 311-22.\*

Articles marked \* may be obtained as a pamphlet from the Royal Geographical Society, price 50p.

*Further reading*

- Allan, A. L., Hollwey, J. R., Maynes, J. H. B. 1968 *Practical field surveying and computations*. Heinemann.  
 American Society of Photogrammetry 1966 *The manual of photogrammetry* (3rd ed.).  
 Clark, D. 1969 *Plane and geodetic surveying. Vol. I: Plane surveying* (6th ed.). Constable.  
 ———, 1973 *Plane and geodetic surveying. Vol. II: Higher surveying* (6th ed.). Constable.  
 Crone, D. R. 1963 *Elementary photogrammetry*. Arnold.  
 Debenham, F. 1956 *Map making*. Blackie.  
 Fagan, P. F. 1967 Surveying in South Georgia, 1964-65. *Survey Review* **XIX**, 146: 159-65.  
 Glendinning, J. and Oliver, J. G. 1972 *Principles and uses of surveying instruments* (3rd ed.). Van Nostrand Reinhold.  
 Hatfield, H. R. 1965 *Admiralty manual of hydrographic surveying. Vol. I*.  
 Hayward, L. M. 1968 *Survey practice on construction sites* (2nd ed.). Pitman.  
 HMSO 1958 *Field astronomy*.  
 Ingham, A. 1974 *Hydrography for the surveyor and engineer*. Crosby Lockwood Staples.



- Kilford, W. K. 1975 *Elementary air survey* (3rd ed.). Pitman.
- Perrot, S. Wright 1970 *Surveying for young engineers* (3rd ed. revised Allan, A.C.). Chapman and Hall.
- Redmond, F. A. 1950 *Tacheometric tables*. Technical Press.
- Robinson, A. N. 1969 *Elements of cartography* (3rd ed.). Wiley.
- Roelofs, R. 1950 *Astronomy applied to land surveying*. Ahrend and Zoon.
- Searles, W. H., Ives, H. C., Kissam, P. 1949 *Field engineering* (22nd ed.). Wiley.
- Smith, J. R. 1970 *Optical distance measurement*. Crosby Lockwood.
- Whyte, W. S. 1976 *Basic metric surveying* (2nd ed.). Newnes-Butterworth.

## APPENDIX

Survey and meteorological instruments and cameras of  
the Royal Geographical Society

The Society maintains a stock of surveying and meteorological instruments and cameras for the use of approved expeditions.

The instruments available are:

*Survey Instruments*

Theodolites  
Magnetic compasses  
Sun compasses  
Telescopic levels  
Abney levels (hand held)  
Sextants  
Range finders  
Ranging poles  
Subtense bars (2-metre)  
Plane tables  
Telescopic alidades  
Altimeters  
Chronometer watches  
Steel and fabric measuring tapes of  
different sizes  
Optical squares

*Meteorological Instruments*

Anemometers (hand held)  
Barographs  
Thermographs  
Rain gauges  
Thermometers (wet and dry)  
Thermometers (max. and min.)  
Stevenson screen (portable type)

*Cameras*

16 mm Cine-cameras (spool type)  
16 mm Cine-cameras (magazine type)  
Polaroid cameras

Further details of these instruments may be obtained from the

Royal Geographical Society  
1 Kensington Gore  
London SW7 2AR



PRINTED IN GREAT BRITAIN BY  
ROBERT MACLEHOSE AND COMPANY LIMITED  
PRINTERS TO THE UNIVERSITY OF GLASGOW

*Price £1.50*